

INSTRUCTION MANUAL

WITHSTANDING VOLTAGE TESTER

MODELS TOS8700 & TOS8750

Third Edition

WARNINGS against **HIGH VOLTAGE**

- o *This tester generates high voltage.*
- o *Any incorrect handling may cause death.*
- o *Read Section 3 "WARNINGS" in this manual to prevent accident.*
- o *This manual should be placed within the reach of the operator so that he may read it whenever necessary.*

KIKUSUI ELECTRONICS CORPORATION
(KIKUSUI PART NO. Z1-210-220)

M-92071

192. 7. 28

895356A

Power Requirements of this Product

Power requirements of this product have been changed and the relevant sections of the Operation Manual should be revised accordingly.

(Revision should be applied to items indicated by a check mark)

Input voltage

The input voltage of this product is _____ VAC,
and the voltage range is _____ to _____ VAC. Use the product within this range only.

Input fuse

The rating of this product's input fuse is _____ A, _____ VAC, and _____.

WARNING

- To avoid electrical shock, always disconnect the AC power cable or turn off the switch on the switchboard before attempting to check or replace the fuse.
- Use a fuse element having a shape, rating, and characteristics suitable for this product. The use of a fuse with a different rating or one that short circuits the fuse holder may result in fire, electric shock, or irreparable damage.

AC power cable

The product is provided with AC power cables described below. If the cable has no power plug, attach a power plug or crimp-style terminals to the cable in accordance with the wire colors specified in the drawing.

WARNING

- The attachment of a power plug or crimp-style terminals must be carried out by qualified personnel.

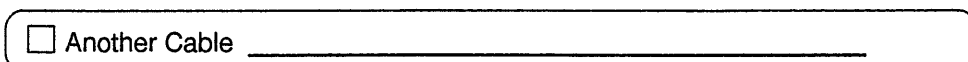
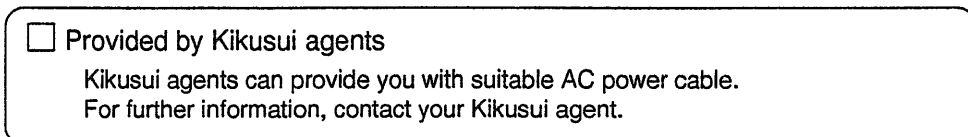
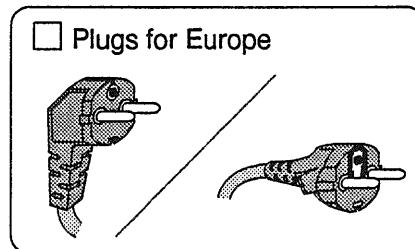
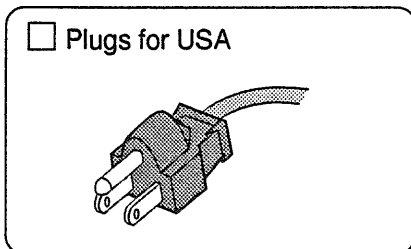
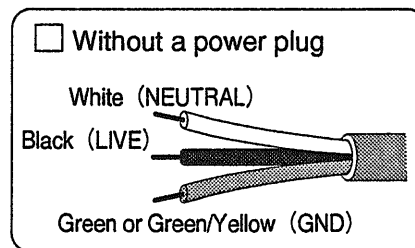
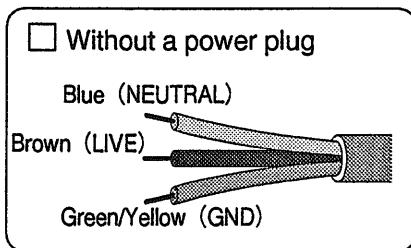

— To supervisor in charge of operation —

- (1) *If the operator does not read the language used in this manual, translate the manual into appropriate language.*
- (2) *Help the operator in understanding this manual before operation.*
- (3) *Keep this manual near the tester for easy access of the operator.*

— Receiving inspection —

Prior to the shipment from our factory, the tester has been subjected to electric- and mechanical-testing and guaranteed of satisfactory quality and performance. Nevertheless, you are kindly requested to make an acceptance inspection to see if the tester has any in-transit damage. Should there be any, please inform our local dealer of such a damage.

— For your own safety (How to avoid electrification) —

(1) While the tester is generating the output, do not touch the following areas, or else, you will be electrified, and run the risk of death by electric shock.

- the output terminal
- the test lead-wire connected to the output terminal
- the Device Under Test (D.U.T.)
- any part of the tester, which is electrically connected to the output terminal, and
- the same part as above immediately after the output has been cut off. (using DC test voltage)

(2) Also, electric shock or accident may arise in the following cases:

- the tester being operated without grounding.
- if the gloves for electrical job are not used.
- approach to any part connected to the output terminal while the power of the tester is turned on.
- the same action as above immediately after the power of tester has been turned off.

= ATTENTION =

Pay attention to the following instructions and those warnings given in the Section 3 "WARNINGS" as well.

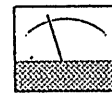

Swinging of the indicator means "high voltage warning"

Read Instruction Manual Page 29 before remote operation.

Be sure to push the RESET button before changing the test condition.

TOS 8750

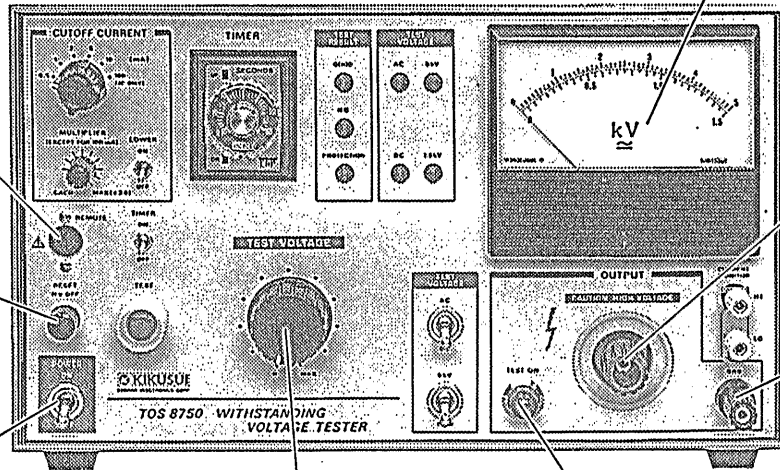

High-voltage output terminal dangerous

Connect with the lead wire on GND side.

Turn on the POWER switch while the TEST VOLTAGE dial is at "0" position.

TEST VOLTAGE dial should be at "0" position except during the testing.

If the lamp comes on, it warns "high voltage"

The rear-side of the tester casing and the protective grounding terminal shall be connected to the earth, using the applicable tool.

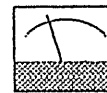

Swinging of the indicator means "high voltage warning"

Be sure to push the RESET button before changing the test condition.

TOS 8700

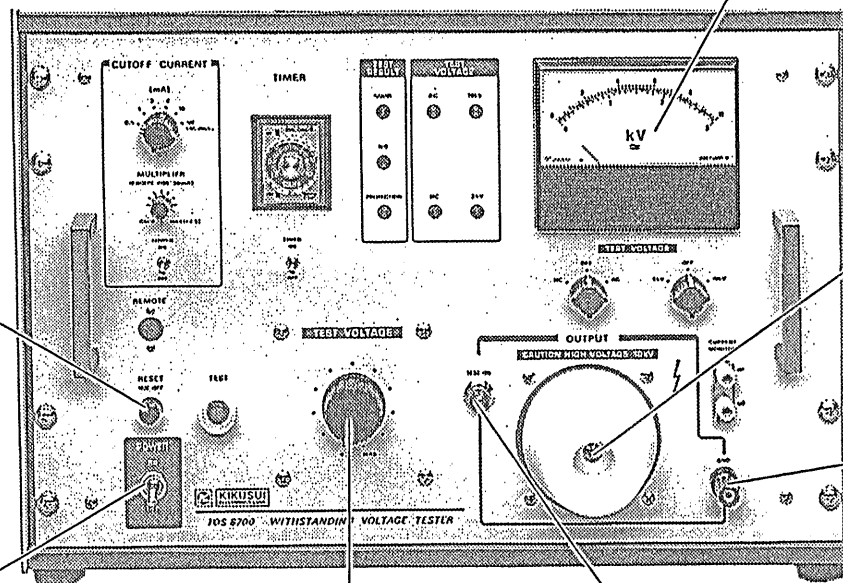

High-voltage output terminal dangerous

Connect with the lead wire on GND side.

Turn on the POWER switch while the TEST VOLTAGE dial is at "0" position.

TEST VOLTAGE dial should be at "0" position except during the testing.

If the lamp comes on, it warns "high voltage"

895359

TABLE OF CONTENTS

	PAGE
1. GENERAL	1
2. SPECIFICATIONS	2
3. WARNINGS	8
4. OPERATION INSTRUCTIONS	18
4.1 Description of Front Panels	18
4.2 Description of Rear Panels	23
4.3 Operating Procedure	25
4.3.1 Procedure Before Test	25
4.3.2 Withstanding Voltage Test Procedure	25
4.3.3 GO-NOGO Judgement (Window Comparator Function and Judgement Errors)	28
4.3.4 Remote Control	29
4.3.5 Output Signals	33
4.3.6 Special Mode Settings for Sequences, Etc.	37
(1) Double-action test-on function	37
(2) GOOD signal hold function	38
(3) Momentary test-on function	38
(4) Current limiting off function (Regulation of the Tester) ...	39
(5) NG ALARM function	41
5. OPERATING PRINCIPLE	42
5.1 Block Diagram	42
5.2 Descriptions of Individual Circuits and Components	42
5.3 Zero-turn-on Switch	44
6. MAINTENANCE	46
6.1 Cautions	46
6.2 Calibration	46
7. OPTIONS	52
<input type="checkbox"/> Model 913A Remote Control Box	52
<input type="checkbox"/> Model 914A Remote Control Box	53
<input type="checkbox"/> HTP-1.5A High Voltage Test Probe	53
<input type="checkbox"/> HTP-3W High Voltage Test Leadwire	54
<input type="checkbox"/> 9202 Warning Light	55
<input type="checkbox"/> 9203 Buzzer Unit	55

1 . GENERAL

Models TOS8750 and TOS8700 Withstanding Voltage Testers are for both AC voltage and DC voltage testing, with an AC output rating of 500 VA. The TOS8750 is for an AC output of 5 kV, 100 mA (500 VA) or a DC output of 5 kV, 25 mA (125 W), and the TOS8700 is for an AC output of 10 kV, 50 mA (500 VA) or a DC output of 10 kV, 10 mA (100 W), and can be used for withstanding voltage test in compliance with JIS, Electrical Appliance Control Ordinance, UL, CSA, BS and other major electrical standards and ordinances. They can be used for withstanding voltage test (dielectric strength test) of the various types of electrical and electronic equipment and components.

The Testers have a GO-NOGO judgement function, a test result output function, and a remote control function. The GO-NOGO judgement function is with a window comparator system. It generates an NG signal when a leak current larger than the judgement reference value set on the front panel has flowed and it also can generate an NG signal when the detected current is less than 1/10 of the set value. With these features, GO-NOGO judgement can be made including to some extent such abnormal states as open circuiting or imperfect contacting of test leadwires. Regarding the test result output function, the Testers deliver a test signal, a GOOD signal or an NG signal, all of which are contact signals. By employing the GO-NOGO judgement function in conjunction with the remote control function, an automated and labor-saving withstanding voltage test system can be realized.

In addition the sequence circuit is designed to be free from erroneous operations caused by noise, making the Testers highly reliable instruments.

Although many safety features are incorporated in the Testers, a deadly accident may occur when the operator touches the device under test (D.U.T.) or the probe.

Safety guards around D.U.T. should be considered for safe operation.

Also, other precaution, which deemed necessary for the tester and the devices, shall be maintained under positive control.

This instruction manual is applicable to both TOS8750 and TOS8700.

Read the items relevant to respective models.

2. SPECIFICATIONS

Model		TOS8700	TOS8750		
Test voltage	Applied voltage		AC/DC		
			0 - 3/0 - 10 kV	0 - 1.5/0 - 5 kV	
	AC	Output (with 100 V AC line)		500 VA (Note 1)	
				10 kV, 50 mA	5 kV, 100 mA
		Waveform		AC line voltage waveform	
		Voltage regulation (with 100 V AC line)		20% or better	
				(For change from maximum rated load to no load)	
	Switching		Zero-turn-on switch (zero-start switch) is used.		
	DC	Output (with 100 V AC line)		100 W	125 W
				10 kV, 10 mA	5 kV, 25 mA
Ripples		10 kV, no load: 120 Vp-p (typical) Maximum rated load: 1700 Vp-p (typical)	5 kV, no load: 40 Vp-p (typical) Maximum rated load: 800 Vp-p (typical)		
Voltage regulation (with 100 V AC line)		20% or better	25% or better		
		(For change from maximum rated load to no load)			
Current limiting (Note 2)		<ul style="list-style-type: none"> ○ A limiting resistor is inserted in the primary circuit of high voltage transformer. ○ When in Ac mode and cutoff current range is 0.5 - 10 mA, the current limiting function is selectable with an internal switch. 			
Output voltmeter	Scales		Common for AC/DC		
			3/10 kV FS	1.5/5 kV FS	
	Class		JIS Class 1.5		
	Accuracy		±3% FS		
AC indication graduation		Mean-value response/rms-value graduation			

895363

Model		TOS8700	TOS8750
Judgement of test result (Cutoff of output by leak current detection)	Judgement system	<ul style="list-style-type: none"> ○ Window comparator system ○ NG judgement when current larger than the set value is detected ○ NG judgement when current is less than 1/10 of the set value is detected ○ When NG judgement is made, the output is cut off and an NG alarm is generated. ○ If no abnormal state is found during the set period, the GOOD signal is generated. 	
	Reference value setting	0.5, 1, 2, 5, 10, 50 mA	0.5, 1, 2, 5, 10, 100 mA
		The highest ranges (50, 100 mA) are for AC only.	
	Multiplier	<ul style="list-style-type: none"> ○ Each of the above setting values can be multiplied up to 2.5 times continuously variably. ○ The scales are non-calibrated. 	
		Except the 50 mA range of AC and 10 and 50 mA ranges of DC	Except the 100 mA ranges of both AC and DC
	Accuracy of judgement (Note 4)	<ul style="list-style-type: none"> ○ With reference to high limit (set value) : $\pm 5\%$ ○ With reference to low limit (1/10 of set Value) : $\pm(20\% + 20 \mu\text{A})$ 	
	Detection system	Absolute value of leakage current is integrated and compared with the reference value.	
	Calibration	Calibrated for rms value of sine wave, using pure resistive load.	
No-load output voltage needed for detection (Note 5)	Approx. 1100 V when at 50 mA AC setting 300 V when at 10 mA DC setting	Approx. 700 V when at 100 mA AC setting 150 V when at 10 mA DC setting	
Dimensions (Maximum dimensions)	497 W × 330 H × 370 D mm (19.57 W × 12.99 H × 14.57 D in.) 500 W × 345 H × 460 D mm (19.69 W × 13.58 H × 16.54 D in.)	350 W × 200 H × 300 D mm (13.78 W × 7.87 H × 11.81 D in.) 360 W × 220 H × 355 D mm (14.17 W × 8.66 H × 13.98 D in)	
Weight	(Note 6)	Approx. 40 kg (89 lb)	Approx. 22 kg (49 lb)

Note 1: The period during which the Testers can be continuously operated with their maximum rated currents is up to 30 minutes.

Note 2: When the cutoff current setting is at the 100 mA (50 mA) AC range or at the 10 mA range and the multiplier is used or when it is at any one of the DC ranges, the current limiting function is cleared unconditionally. (The value enclosed in the parentheses is for the TOS8700.)

Note 3: Slight are discharge may occur in the TOS8700 when its output voltage is set at 6 kV or over in ambient humidity 75% or over. This, however, is a normal indication and does not adversely affect the instrument operation.

Note 4: ① When the output voltage is set at a low voltage in the DC mode, larger errors may be caused by ripples. The specification accuracy is met when the output voltage is 500 V or over for the TOS8700 or 200 V or over for the TOS8750.

② When in the AC mode, the current which flows through the stray capacitances of the output circuit and measuring leads also causes measuring errors. The overall judgement error is the sum of this current and the above-mentioned judgement accuracy. Approximate values of such currents are shown in the following table. Note that, at high-sensitivity high-voltage test, the current which flows through the stray capacitances becomes larger than the low-limit judgement value and low-limit judgement may not be successfully made.

Output voltage	2 kV	4 kV	6 kV	8 kV	10 kV
Main unit only (without measuring leadwires)	8 μ A	16 μ A	24 μ A	32 μ A	40 μ A
When 350-mm-long leadwires are used being suspended in air	12 μ A	24 μ A	36 μ A	48 μ A	60 μ A
When the accessory leadwires (HTL-1.5W) are used	40 μ A	80 μ A	120 μ A	160 μ A	200 μ A

895365

Note 5: Due to the internal resistance of the output circuit, to make NG judgement with the output terminals shorted, a certain level of no-load output voltage is needed. The values of such voltages are shown in the preceding table.

Note 6: Approx. 4kg increase when in line voltage modified.

Common Items

Test voltage waveform:

When an AC voltage is applied to a capacitive load, the output voltage may become higher than that when in no load due to the capacitive components of the load. Especially when the load (specimen) is of a voltage-dependent capacitance type (such as ceramic capacitors), the voltage waveform may be distorted. When the test voltage is 1.5 kV, however, effects caused by a capacitance lower than 1000 pF is negligible.

Test time:

Timer setting time: 2 - 60 sec. (with timer OFF switch)

Remote control:

(1) The test/reset operation can be remote-controlled in the following cases:

- When the Remote Control Box (optional) is used.
- When the High Voltage Test Probe (optional) is used.
(CAUTION: THE TEST VOLTAGE MUST NOT BE HIGHER THAN 5 kV.)
- When the instrument is controlled with a make-contact of a relay or a switch.
- When low-active control is made with logic elements. The input conditions of the Testers in this case are as follows:
 - HIGH level input voltage: 11 - 15 V
 - LOW level input voltage: 0 - 4 V
 - LOW level sweepout current: 2 mA or less

895366

Note 7: The input terminals are pulled up to +15V supply voltage by a resistor. If the input terminals are made open, the state is identical with that a HIGH level input is applied.

- (2) The Tester can be set to the protected state (the state that TEST ON is disabled) by making open the protection input terminals which normally are shorted with a shorting bar.

Leak current monitor terminals:

When checking or calibrating the cutoff current, an AC or DC milliammeter to monitor the AC or DC current may be connected to these terminals.

Output signals:

The types of the output signals available and the conditions of their generation are as follows:

Name of signal	Conditions for signal generation	Type of signal
TEST signal	During the period the test is performed	Make-contact signal, lamp
GOOD signal	When GOOD judgement is made, 200 msec	Make-contact signal, lamp, buzzer
NG alarm	When NG judgement is made, continuous	Make-contact signal, lamp, buzzer

Note 8: (1) The rating of the contact signal are 100 V AC, 1 A, or 30 V DC, 1 A.

- (2) Loudness of the buzzer sound is adjustable with a single knob in common for both GOOD and NG signals.

895367

Ambient conditions:

Temperature and humidity

to meet specified performance: 5 to 35°C (41 to 95°F), 20 to 80% RH

Operatable temperature and humidity: 0 to 40°C (32 to 104°F), 20 to 80% RH

Power Requirements:

Line voltage: 100 V \pm 10%, 50/60 Hz AC
(Can be factory-modified to nominal 110V, 115V, 120V, 200V, 220V, 230V and 240V.)

Power consumption: 15 VA or less when no load (in the reset state)
(Note 9)
Approx. 600 VA when with rated load

Insulation resistance: 30 M Ω or over, with 500 V DC

Withstanding voltage: 1000 V AC, 1 minute

Note 9: Power consumption of the instrument modified to operate on an AC line voltage other than 100 V is as follows.

110/115/120 V : 25 VA or less

200/220/230/240 V: 45 VA or less

Accessories:

- High Voltage Test Leadwires, HTL-1.5W 1 set
(5 kV or lower)
- High Voltage Test Leadwire, HTL-1.5WH 1 (for TOS8700 only)
(higher than 5 kV)
- Shorting Bar to Remote Protection Terminal 1 (Installed on main unit)
- Shorting Bar for Current Monitor Terminal 1 (Installed on main unit)
- "HIGH VOLTAGE DANGER" label 1
- Instruction Manual 1
- 5P DIN Plug (assembly type) 1

Note 10: The "High Voltage Test Leadwire, for 10 kV" which is supplied as an accessory of the TOS8700 is a silicone-sheated cable with a diameter of approximately 12 mm. Be sure to use this cable when the test voltage is higher than 5 kV.

191 12 16
TOS8700/8700
895368B

3. WARNINGS

The tester supplies high voltage up to 5kV (or 10kV in the case of Model TOS8700) to the outside connection.

Thus any incorrect handling of the tester may bring the risk of death to the operator. For safe operation of the tester, strictly observe the following instructions.

1. Electrification

Be sure to wear a pair of rubber gloves for electrical job, before operating the tester, to prevent electric shock.

2. Grounding:

The protective grounding terminal, on the rear of the tester casing, shall be positively grounded using the applicable tool.

If not properly grounded, the casing of this tester is charged with high voltage when the power is short-circuited to the ground or conveyer or any devices connected to the ground or to the commercial power line (Note i).

It is very risky that anyone who touches the casing under such a condition will be subject electric shock.

(Note i) Generally a commercial power line means a line leading to the AC cord socket of the tester, from which the rated power is supplied into the tester.

This manual also covers the power supply line from a private power generator.

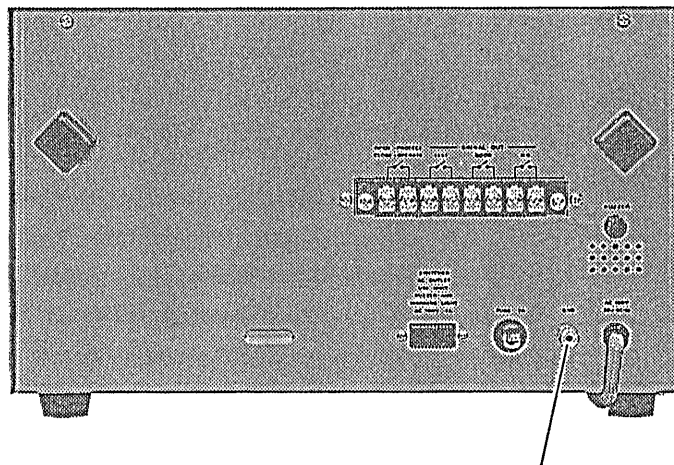

Figure 3.1 Rear of Casing, Model TOS8750 Protective grounding terminal

Protective grounding terminal

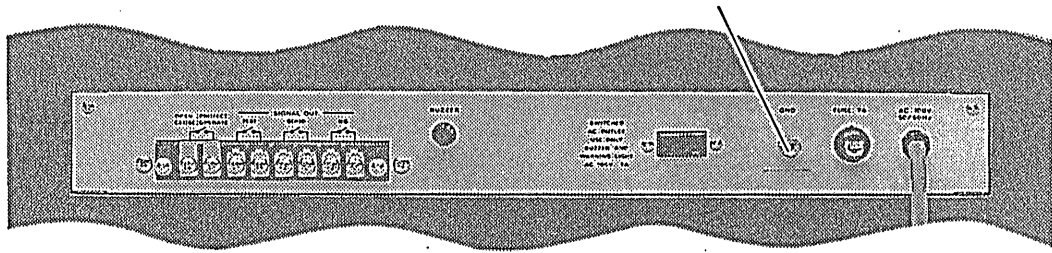

Figure 3.2 Rear of Casing, Model TOS8700

3. Connecting of test lead-wire on GND side:

Figure 3.3 shows the connection of the test lead-wire on GND side. Every time the tester is used, check if the lead wire is not damaged or disconnected.

The lead-wire connection to the D.U.T. shall be made from GND side. If the connection is incomplete, it is hazardous that the entire D.U.T. may be charged with high voltage.

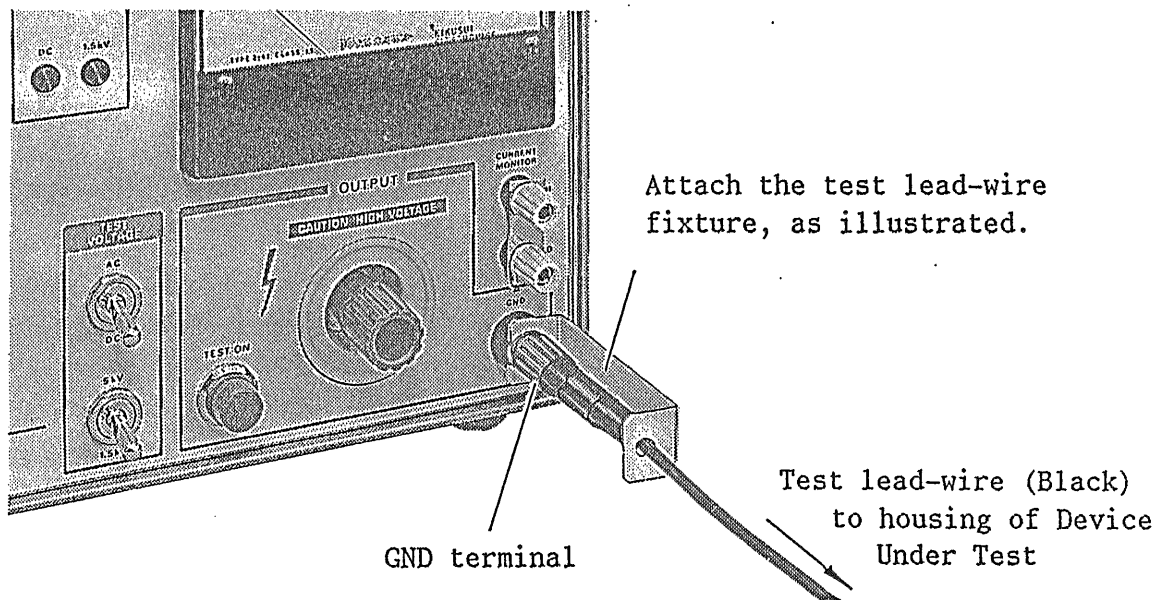

Figure 3.3

895370

4. Connection of test lead-wire on high-voltage output side:

After connecting the lead-wire on GND side, take the following procedure.

- Push the RESET button.
- Confirm if the indicator of the output voltmeter is at "0".
- Confirm if the TEST ON lamp has been off.
- Short the high-voltage output terminal with the GND test lead-wire once, and confirm that no high voltage is output.
- Connect the high-voltage test lead-wire with the high-voltage output terminal.
- Lastly, connect the GND test lead-wire and then the high-voltage output test lead-wire to the D.U.T.

5. Power source switch:

The power switch shall be turned on after confirming that the TEST VOLTAGE dial has been turned to the extreme left ("0" position).

6. Change of test condition:

Change-over of the switches on the panel shall be made after confirming that the RESET button has been pushed in and that the TEST VOLTAGE dial has been turned to the extreme left ("0" position).

7. Suspension of testing:

Except under testing the TEST VOLTAGE dial shall be turned to the extreme left ("0" position).

Also, push the RESET button (H.V OFF) to ensure safety.

The Power switch shall be turned off if the tester is not used for some time or the operator is to leave from the tester.

895371

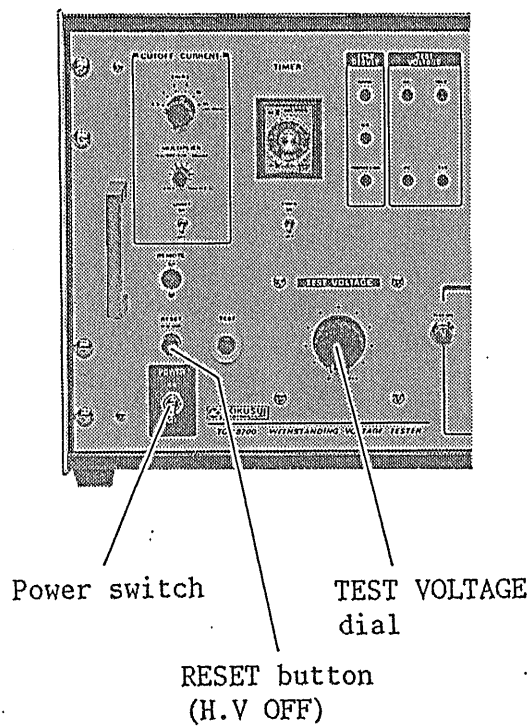

Figure 3.4

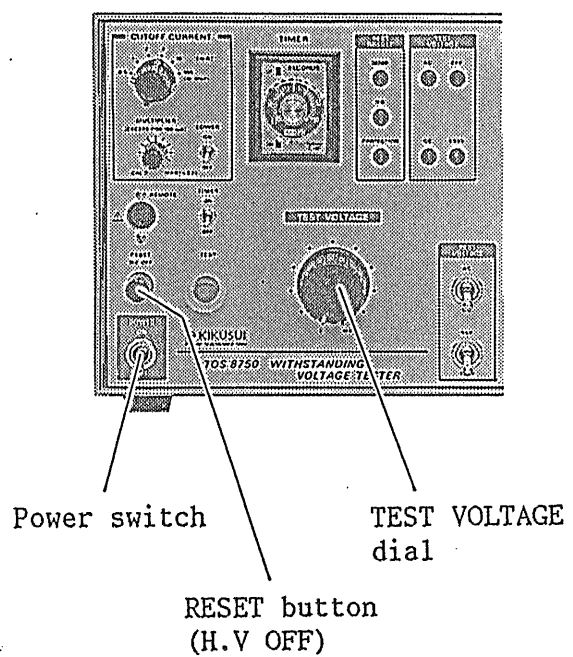

Figure 3.5

8. Critical areas of the tester under operation:

It is dangerous to touch such high voltage areas as the D.U.T., and the test lead-wire, probe and output terminal while the tester is under operation.

Never touch this area!

NEVER touch the alligator of the test lead-wire and the vinyl-cover of the clip because they are NOT insulation proof.

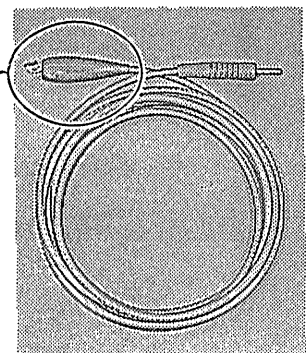

Figure 3.6

— Warning after the output has been cut off —

9. Confirmation on completion of testing:

You may touch the D.U.T. and the high-voltage areas (test lead-wire, probe or output terminal) for correction of the wiring or any other purpose provided that the following confirmation has been made beforehand;

- the indication of output voltage is at "0", and
- the TEST ON lamp has been turned off.

When the test voltage has been output by DC mode, the D.U.T. is electrically charged. Therefore, a particular attention must be paid to the succeeding paragraphs, 10 and 11.

— Cautions in electric charging in DC mode —

10. Electric charging:

When the test voltage is output in DC mode, the D.U.T. and capacitor, test lead-wire, probe and output terminal, embodied in the tester, are charged with high voltage.

And it takes some time to discharge such an electric charge after the power has been cut off.

Accordingly, you should not touch such areas to prevent electric shock for a while after the power has been turned off.

After confirming that the indication of the output voltage is at "0", short the GND terminal and the high-voltage output terminal, using the GND test lead-wire, to discharge the electric charge in the above areas.

11. Confirmation on discharge of electric charge

The time required to discharge electric charge differs depending on the properties of D.U.T., applied test voltage and model in use (TOS8700 or TOS8750).

When the D.U.T. is not connected, the discharge time of internal capacitor in this tester individual is as listed below.

Discharge time in this tester individual

Test voltage Model	5 kV	10 kV
TOS8700	Approx. 9 sec	Approx. 10 sec
TOS8750	Approx. 11 sec	

(The time required to attenuate the voltage of output terminal down to 30V)

When the D.U.T. is connected, the above values vary greatly depending on the properties of the D.U.T..

Suppose that high voltage areas such as D.U.T., test read-wire, etc. could be expressed in an equivalent circuit as illustrated in Figure 3.7, the time to discharge from such areas, can be determined as per the table below.

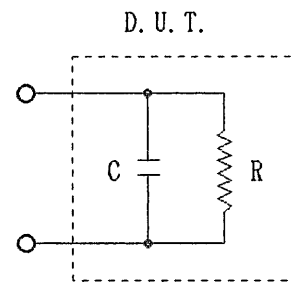

Figure 3.7

REQUIRED time to discharge from D.U.T.

Test volt Model	5 kV	10 kV
TOS8700	Approx. $9 \times (1 + \frac{C}{0.05})$ sec	Approx. $10 \times (1 + \frac{C}{0.05})$ sec
TOS8750	Approx. $11 \times (1 + \frac{C}{0.2})$ sec	

- C unit is μF
- The time requested to attenuate the voltage of D.U.T. down to 30V

895374

12. Remote controll of tester:

In the case this tester is to be remote controlled, the application of high voltage to the tester will be controlled by an external signal.

Take the following safety precautions to prevent accident. Also, shall be maintained the safety precaution under positive control.

- NOT to permit unexpected output of high voltage from the tester (that is, to prevent this tester from being put in TEST ON condition).
- NOT to permit operator and any other come into contact with D.U.T. test lead-wire, probe, output terminal, etc. while the tester is generating high test voltage.

13. Re-turn on of POWER switch:

Once the Power switch of the tester has been turned off, leave at least several seconds before it is turned on again. Do not repeat ON-OFF switching of the Power switch particularly when the tester is generating the output voltage. In such a case, the safety protection of the tester may not work properly, and the operater is endangered.

The power switch shall not be turned off while the tester is generating the output voltage except in the case of emergency.

14. Other precaution:

Do not short-circuit the tester output with the ground or a conveyer or any device connected to the ground, or with the comercial power-line around tester location. Such a short-circuit may cause high-voltage charging on the tester casing, which is very dangerous.

However, such a risky condition will not arise if only the casing has been ground, in which case the casing will not be electrically charged nor will cause the damage on the tester even when the GND terminal has been short-circuited with the high-voltage terminal.

The protective grounding terminal shall be positively grounded using applicable tool.

895375

— In case of Emergency —

15. Emergency handling:

In the case of any accident such as an electric shock or burn-down of the D.U.T. resulting from the failure of the tester or D.U.T. take the following actions promptly;

- cut off the POWER switch, and
- pull out the plug of AC cord from the socket of the power source.

It does not make any difference whichever action of the above two is taken first, but be sure to take the two actions.

— Trouble-shooting —

16. In case of trouble:

In the following cases of trouble, it is very hazardous that the power of the tester may not be cut off while the tester continues to generate high voltage:

- TEST ON lamp keeps on lighting even when the RESET button has been pushed.
- TEST ON lamp is turned off but the indicator of the output voltmeter continues swinging.

The immediate action to take, in the above cases, is to pull out the plug of AC cord from the the socket of the power source, and suspend the operation of the tester.

Thereafter, entrust us with the trouble-shooting and repair of your defective tester.

If the tester shows any irregular performance, it is possible that a high voltage may be output irrespective of the operator's will.

Suspend the operation of the tester immediately.

17. Fade out of TEST ON lamp:

In the case the TEST ON lamp has been faded out, it may cause erroneous operation of the tester, which in turn give rise to dangerous electrification.

Please entrust us with the repair of such a defective tester.

◆◆ Attention for Trouble-Free Operation ◆◆

(1) The max. output voltage of this tester reaches higher than 5kV (or 10kV in the case of Model TOS8700) under no-load condition, and even higher voltage in proportion to the power-supply fluctuation. But be sure to operate the tester at a lower voltage than the specified 5kV (or 10kV).

(2) The heat dissipation capacity of the high-voltage transformer, embodied in the tester, is designed to be a half of the rated output, taking into consideration of the size, weight and cost.

Accordingly, if the test is to be conducted at the CUTOFF CURRENT of 100mA (or 50mA in the case of Model TOS8700), leave a suspension time longer than the test duration.

Incidentally, the max. allowable test duration is 30 minutes at ambient temperature of 40°C (104°F) or lower.

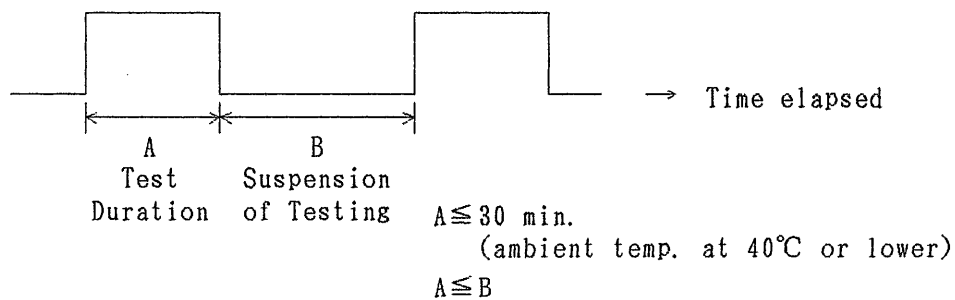

Figure 3.8

The above timing is not applicable if the tester is used at the CUTOFF CURRENT setting of 10mA or lower.

895377

- (3) This tester can be properly used with the input power supply of nominal input voltage $\pm 10\%$, but its operation becomes incomplete outside of this range and leads to possible failures.

It is thus important to adjust the power supply within the range of nominal input voltage $\pm 10\%$ by any proper means.

- (4) The operation and storage of the tester under exposure to the direct sunshine, high temperature and humidity or dusty environment should be avoided.

- (5) This tester is incorporated with a transformer of high output voltage up to 500VA.

A considerably large current (in scores of amperes) may flow through the commercial power line, which is connected with the tester in the following two cases:

- In the duration of scores of milli-sec., in which the tester detects that a D.U.T. has failed the testing.
- At an instant when the test is executed.

Also it is important to determine the capacities of the power line and of any electronic device connected to the same line, taking into consideration of such a large current.

4. OPERATION INSTRUCTIONS

4.1 Description of Front Panel

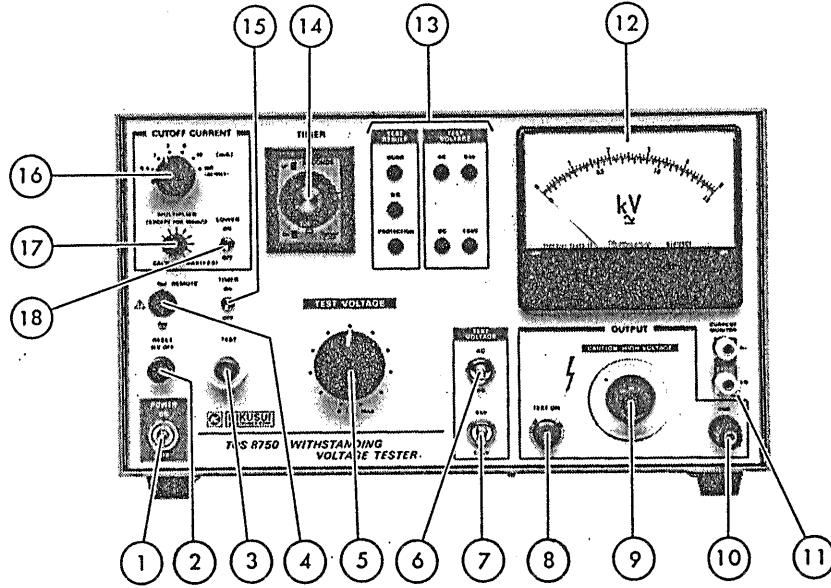

Figure 4.1 Model TOS8750

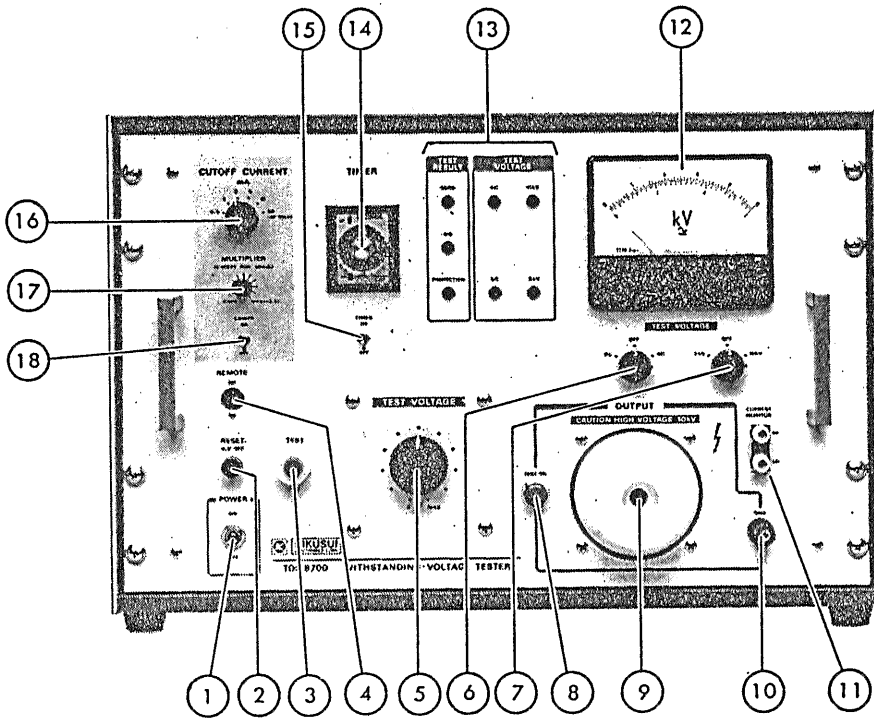

Figure 4.2 Model TOS8700

895379

① POWER (ON/OFF) switch:

Main power switch of instrument. Before turning on this switch, be sure to read Section 3 "WARNINGS."

② RESET button (HV OFF):

To cut off the HV output when in test operation, press this button. This button is used also to reset the NG alarm state or the PROTECTION state.

③ TEST button:

As you press this button when the instrument is in the reset state, the TEST ON lamp lights and the test voltage as set by the TEST VOLTAGE dial is delivered to the output terminal.

④ REMOTE CONTROL connector:

When the instrument test/reset is remote controlled, the cable of the remote control box (Model 913A, 914A,) is connected to this connector. It also is used to connect other control signal. Be sure to read Section 4.3.4 "Remote Control" before operating the Tester in the remote control mode.

⑤ TEST VOLTAGE dial:

For setting the withstanding test voltage. The "0" position is for the minimum output and the voltage increases as this dial is turned clockwise. Be sure to keep this dial in the "0" position whenever no test is being done.

⑥⑦ TEST VOLTAGE selectors (The ones enclosed in the parentheses are for the TOS8700.)

○ AC/DC (AC/OFF/DC) switch:

To select the AC mode or the DC mode for the test voltage. (When this switch is set to OFF, the instrument is in the PROTECTION state and no test voltage is delivered even if the TEST button is pressed.)

- 1.5kV/5kV (3kV/OFF/10kV) switch:

This switch is to select a test voltage range. It is linked to the voltmeter range selector. (The OFF position is for the PROTECTION function the same as above.)

- ⑧ TEST ON lamp:

This red lamp indicates that the test voltage can be delivered to the OUTPUT terminal simply by turning ⑤ TEST VOLTAGE dial or the test voltage is being delivered.

- ⑨ OUTPUT terminal:

The hot line of the test output voltage.

- ⑩ GND terminal:

The ground line of the test voltage. Electrically, this line is connected to the instrument chassis.

- ⑪ CURRENT MONITOR terminals:

The cutoff current can be directly monitored by disconnecting the shorting bar from these terminals and connecting a milliammeter (AC/DC) between them. The milliammeter should be capable of measuring the cut-off current.

Be sure to connect the shorting bar when no milliammeter is connected between these terminals.

- ⑫ Voltmeter:

Indicates the output voltage (the voltage at the high voltage output terminal).

- ⑬ Indicator lamps (The items enclosed in the parentheses are for Model TOS8700.)

- TEST VOLTAGE, 1.5kV/5kV (3kV/5kV)

These red lamps indicate the test voltage range selected.

○ AC/DC

These lamps indicate whether the test voltage is AC or DC.

○ TEST RESULT, GOOD/NG

The GOOD lamp turns on if the result of judgement is good or the NG lamp turns on if it is no good. The NG lamp lights continuously, while the GOOD lamp lights only for about 200 msec. If the timer is not used for test, the GOOD judgement is not done.

○ PROTECTION

When in any of the following cases, the Tester is driven into the protected state and the output is cut off. When this state has occurred, eliminate the cause of trip of the protective circuit and then press the RESET button to reset the Tester.

- (1) When the TEST VOLTAGE selector [⑥ AC/DC (AC/OFF/DC) switch or ⑦ 1.5kV/5kV (3kV/OFF/10kV) switch] is operated for test mode change. (when the selector is turned to the OFF position.)
- (2) When the REMOTE CONTROL connector is disconnected or connected.
- (3) When the REMOTE PROTECTION input terminals are made open.
- (4) When the power switch is turned on again after turning it off only for a short period of time.
- (5) When the cutoff current is set at 100 mA (50 mA) in the DC mode.
- (6) (When in the DC mode the cutoff current is set at 10 mA and the MULTIPLIER function is effected.)
- (7) When the cutoff current is set at 100 mA (50 mA) and the MULTIPLIER function is effected.

⑭ TIMER:

For test time setting. The center knob is for time setting.

⑮ TIMER ON/OFF switch:

To select whether the timer is to be used or not. If the switch is set for ON, the test is executed for the period set by the timer. If it is set for OFF, the test is executed continuously until the NG judgement is made or a reset signal is applied.

⑯ CUTOFF CURRENT [mA]:

This knob is to set the leak current detection reference value to the 0.5, 1, 2, 5, 10, or 100 (50) mA. If a leak current larger than the set reference value flows in the D.U.T., the Tester makes the NG judgement, cuts off instantaneously its output, and generates the NG alarm signal. The reference value should be set in conformity with the specification of the D.U.T. or other requirement.

(The value enclosed in the parentheses is for the TOS8700.)

⑰ MULTIPLIER:

This control is capable of multiplying the reference value (which has been set by the CUTOFF CURRENT knob) by a factor of up to 2.5 times continuously variably. In this case, the scales are non-calibrated. The values set by the CUTOFF CURRENT knob are as calibrated with the MULTIPLIER knob set in the CAL'D position.

⑱ LOWER ON/OFF switch:

The Tester generates the NG signal when a current larger than the set value is detected and it also can generate the NG signal when the detected current is less than 1/10 of the set current. This switch selects whether the latter function is to be effected or not.

4.2 Description of Rear Panels

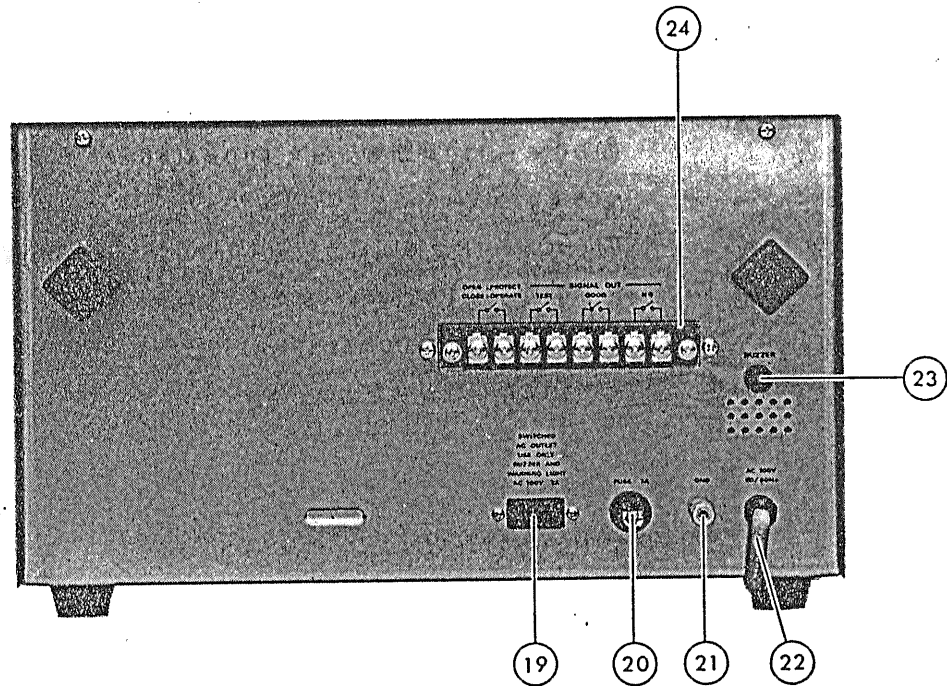

Figure 4.3 Model TOS8750

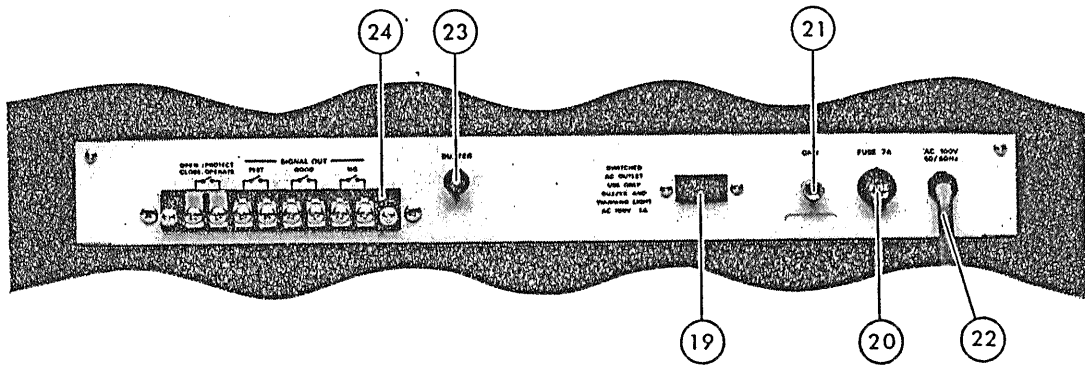

Figure 4.4 Model TOS8700

① AC OUTPUT receptacle:

This AC receptacle provides a 100-VAC power exclusively for Model 9202 Alarm Lamp Unit or Model 9203 Buzzer Unit, which are optional devices. Do not use this AC receptacle for other devices. The power of this receptacle is on/off-controlled being linked to the POWER switch on the front panel.

895384

⑩ Fuse:

Fuse of the AC power line.

Nominal Voltage	Fuse	
	TOS8750	TOS8700
100 V, 110 V 115 V, 120 V	7 A	7 A
200 V, 220 V 230 V, 240 V	4 A	4 A

⑪ Protective GND terminal:

To ground the instrument to an earth ground. Be sure to ground the instrument to the earth via this terminal.

⑫ AC xxxV 50/60 Hz

The AC input power cord of the instrument

⑬ BUZZER loudness control:

Controls the loudness of sound of the NG/GOOD buzzer.

⑭ Signal output and remote protection input terminal block

○ SIGNAL OUT terminals:

These terminals provide three types of output signals (contact signals), namely, TEST signal, GOOD signal, and NG signal. For details, refer to Item "Output Signals" of section 4.3.5.

○ PROTECT/OPERATE terminals:

These terminals are for the remote protection input signal. Normally, these terminals are shorted with a shorting bar. If these terminals are made open, the Tester is set to the PROTECTION state and the TEST ON state is disabled.

895385

4.3 Operating Procedure

4.3.1 Procedure Before Test

- (1) Before turning on the instrument power switch, check that the voltmeter is indicating the "0" scale position. If the meter is not indicating the "0" positions, adjust it to this position with its mechanical zero adjustment at its center. If the instrument power has been on, turn it off and then check the meter.
- (2) After thoroughly reading and noting the items of Section 3 "WARNINGS," turn on the POWER switch and proceed as explained in this section.
- (3) If the PROTECTION indicator lamp on the front panel is lighted, the test is disabled and no test is executed even when the TEST button is pressed. The conditions of lighting of this indicator lamp are as mentioned in Item ③ of Section 4.1. To execute the test, eliminate the condition which causes lighting of this lamp and then press the RESET button to reset the instrument.

4.3.2 Withstanding Voltage Test Procedure

- (1) Selecting the test voltage mode:

Select the AC or the DC mode with the TEST VOLTAGE AC/DC switch as required by the D.U.T..

- (2) Precautions for test in the DC mode:

If the test is to be conducted with DC mode, due care must be paid on the following points:

- Bear in mind that the capacitor, test lead-wire etc in the tester and the D.U.T. electrically charged once a test has been conducted and the test voltage generated.
- It is unsafe to touch your hands or body with the high-voltage areas (test lead-wire, probe or output terminal) of the tester and the D.U.T. in a while after the output has been cut off.
- It take some time before the electric charge has been discharge even after the output is cut off by the RESET button or other operations.

If the test has been conducted in DC mode, first of all take the following two actions, or it may eventually cause electric shock or other accident.

- (a) Confirm that the indicator of the output voltmeter is "0".
- (b) After making the above confirmation, short the GND terminal and the high-voltage output terminal once, using the GND test lead-wire.

(3) Selecting the test voltage range:

Select the test voltage range at 1.5 kV or 5 kV (3 kV or 10 kV) with the TEST VOLTAGE selector switch, as required by the D.U.T.. The corresponding one of the TEST VOLTAGE indicator lamps will light. (The values enclosed in the parentheses are for the TOS8700.)

(4) Setting the leak current limit reference value:

With the CUTOFF CURRENT knob, set the leak current limit reference value as required by the D.U.T..

(5) Setting the test time:

Set the test time with the timer, as required by the D.U.T..

(6) Setting the test voltage:

Set the TIMER ON/OFF switch and the CUTOFF CURRENT LOWER ON/OFF switch to the OFF state. If the PROTECTION lamp is not lighted, check that the TEST VOLTAGE dial is at the counterclockwise extreme position, and then press the TEST button. Gradually turn clockwise the TEST VOLTAGE dial to set the required test voltage. Press the RESET button to cut off the output and then set the TIMER ON/OFF switch to the ON state.

(7) Connecting the D.U.T.:

First of all, make sure that "the output voltmeter indication is 0" and "the TEST ON lamp is OFF." Next, connect the GND-side test leadwire to the GND terminal of the Tester and, with this leadwire, short the high voltage output terminal of the Tester to make sure that it is not charged to a high voltage. Next, connect the high-voltage-side leadwire to the high voltage output terminal of the Tester. Connect the GND-side leadwire to the D.U.T. and then connect the high-voltage-side leadwire to the D.U.T..

895387

(8) Test procedure:

- (a) Press the TEST button so that the test operation commences.
- (b) When the period set by the timer has elapsed, the test voltage is cut off and the GOOD signal is generated in the forms of lamp and buzzer and make-contact signal for about 200 msec.
- (c) When a leak current larger than the limit value set by the CUTOFF CURRENT knob has flowed, the NG judgment is done and the output is instantaneously cut off and the NG alarm signals with a lamp, buzzer and make-contact are generated. Different from the case of the GOOD signal, the NG alarm signals continue until the instrument is reset or a PROTECTION condition is applied. To reset the NG alarm signals, press the RESET button.
- (d) When the test in progress is needed to be stopped (the output voltage is needed to be cut off) due to any reason, press the RESET button.

(9) Test without using the timer

- (a) The timer of the instrument is for 60 seconds maximum. When a test time longer than this or that of unpredictable time is needed, perform the test without using the timer. When a test is done with the CUTOFF CURRENT RANGE 100-mA (50-mA) setting, however, a continuous test of up to 30 minutes can be done. This, however, does not apply when the set range is 10 mA or lower. (The value enclosed in the parentheses is for the TOS8700.)
- (b) Set the TIMER ON/OFF switch to the OFF position.
- (c) Connect the D.U.T. to the output terminals of the instrument as explained in Step (7).
- (d) Check that the TEST VOLTAGE dial is at the counterclockwise extreme position and then press the TEST button. The TEST ON lamp will light to indicate that the test voltage is ready to apply. Gradually turn clockwise the TEST VOLTAGE dial until the necessary test voltage is obtained. When the required test time has elapsed or when the required condition is obtained, press the RESET button. In this case the GOOD signal is not generated.

895388

- (e) If the NG alarm signal is generated in the above test, the instrument operations are the same with those occur when the test is done using the timer.

(10) Re-application of test voltage (retest):

If the instrument is in the reset state, the test voltage as set by the TEST VOLTAGE dial is delivered to the output terminal simply by pressing the TEST button. If the instrument is generating the NG alarm signal or is in the PROTECTION state, press the RESET button to reset the instrument. If the GOOD judgment is done at the end of the test, the auto reset circuit operates and the instrument is automatically reset.

4.3.3 GO-NOGO Judgement (Window Comparator Function and Judgment Errors)

(1) Window comparator function:

The window comparator function is such that a GOOD (or an OK) judgment is made only when the measured value is within a range between the high limit and the low limit of a reference span.

(2) GO-NOGO judgment function:

The Testers employ a window comparator system for its GO-NOGO judgment. It makes a GOOD judgment only when the measured value is between the high-limit reference value and the low-limit reference value. That is, it makes an NG judgment when the leak current (measured value) is larger than the set value (high-limit reference value) and it also can make the NG judgment when the current (measured value) is smaller than 1/10 of the set value (low-limit reference value).

The window comparator function can be effectively employed when ununiformity of leak current of the D.U.T. is within a certain range and the leak current value is larger than the value detectable by the Tester. In this case, even the D.U.T. with very small leak currents can be detected and open circuiting of the test leadwires and imperfect contacting of the test leadwires connections also can be detected.

When test voltage setting is done in the no-load state or when almost no current flows in the D.U.T., however, it would be inconvenient if the low-limit judgment is abled. In such a case, the low-limit judgment can be disabled by setting the LOWER ON/OFF switch to the OFF state.

- (3) When high sensitivity, high AC voltage test is made, a larger current may flow due to the stray capacitances of the test leadwires, etc. See Note 4 of Section 2 "SPECIFICATIONS." If this current is larger than the low-limit reference value, the low-limit judgment cannot be successfully made. That is, as the D.U.T. is not connected to the Tester, it should generate an NG signal. However, since a current larger than the low-limit reference value is flowing through the stray capacitances, the Tester will erroneously do a GOOD judgement. Pay attention to this when making an overall judgment.

Make sure that the Tester can generate an NG signal in the actual test conditions with only difference that the D.U.T. is not connected to the test leadwires.

4.3.4 Remote Control

- (1) The test/reset operation of this instrument can be remotecontrolled with the remote control box (option). As the plug of the remote control cable is connected to the REMOTE CONTROL connector on the instrument front panel, the internal circuit is automatically switched to the remote operation mode. In this case, the TEST button on the instrument front panel becomes idle, although the reset operation can be done either locally on the instrument front panel or remotely from the remote controller.

It also is possible to remote-control the instrument without using the remote control box but by using other control device. This method is explained below.

Be extremely careful when using this method because the high voltage is on/off-controlled with an external signal. Pay attention so that the high test voltage is not generated inadvertently. Also, provide full measures to ensure that nobody is contacted with the high voltage areas (D.U.T. test lead-wire, probe or output terminal etc.) when the test voltage is being delivered.

When these measures are unavailable, do not use the following remote control method.

- ① Because the instrument can operate by remote control, the pin No.2 and No.3 of connector must be externally connected.

- ② By controlling the TEST and RESET contacts shown in Figure 4.5, the test voltage can be on-off controlled in the same manner as done locally on the instrument front panel.
- ③ In the case of the setup shown in Figure 4.6, the test voltage is turned on when the switch is thrown to the NO Position, and instrument is forcefully reset when the switch is returned to the NC position.

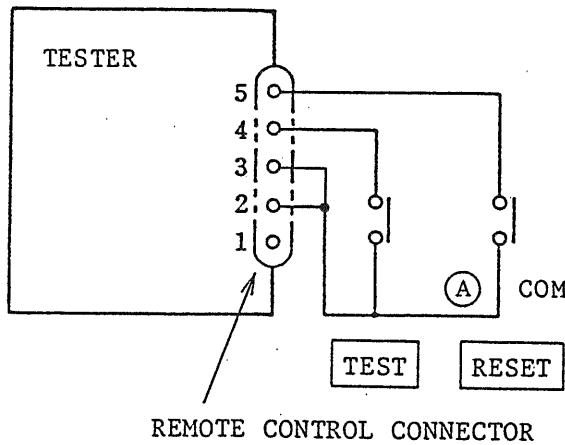

Figure 4.5

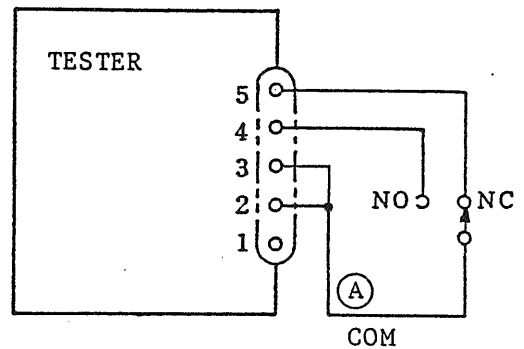

Figure 4.6

- ④ Logic elements (transistors, FET's, or photocouplers) may be used instead of the switches in Figure 4.5. The signal status for such operation is shown in Figure 4.7. The input conditions of this instrument for such operation are as follows:

- High level input voltage: 11 - 15 V
- Low level input voltage: 0 - 4 V
- Low level sweep out current: 2 mA or less
- Input signal duration needed: 20 msec minimum

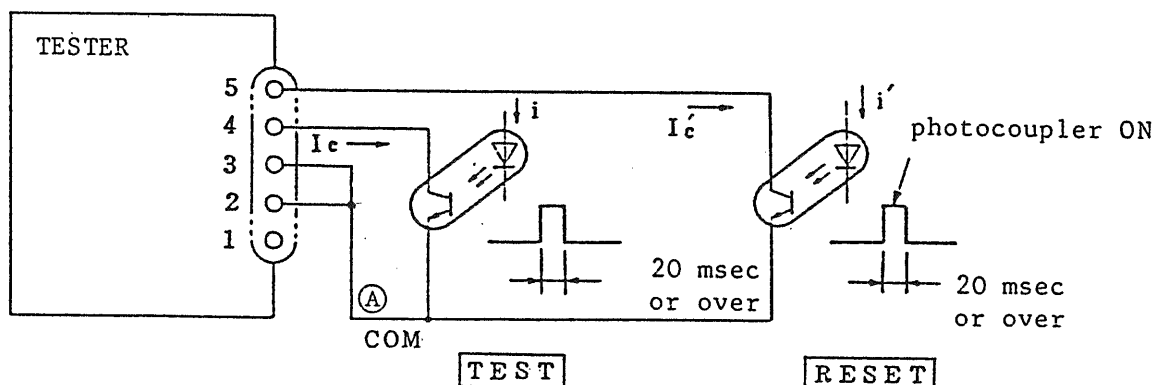
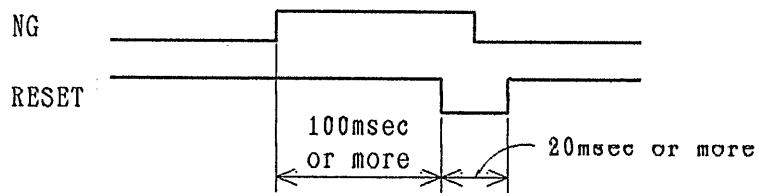

Figure 4.7

192. 7. 28

895391A

- Notes: 1. Each of the gates is pulled up to ± 15 V. If the input terminal is made open, it becomes equivalent with that a high level input is applied.
2. Pay attention for i and i' so that I_c and I_c' can be pulled by 2 mA or over.
3. An impedance of $5\text{ M}\Omega$ or over is needed between the common line (point (A) in Figure 4.7) of the control circuit and the power line or the ground line.
4. The timing of the RESET signal for clearing the NG alarm is as follows.



- ⑤ As for the elements to be connected to the Tester, the use of photo-couplers as shown in Figure 4.7 or relays as shown in Figure 4.5 would be advantageous from the viewpoint of preventing erroneous system operations which could be caused by noise. Although the Testers are incorporated with the various provisions to guard it against erroneous operations caused by noise generated by itself or its related devices, it is most recommendable to take full attention to prevent noise when setting up the measuring system.
- ⑥ Note that the layout of pins of the REMOTE CONTROL connector is as per DIN Standard and is not in the due order of number progression as shown in Figure 4.8.

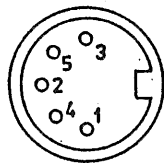

Layout of connector pins as viewed from panel surface

Figure 4.8

192 7 28

895392A

- (2) As one of the remote control functions, the Tester can be driven into the PROTECTION state with an external signal. The PROTECTION state is such that the protective function of the Tester is in effect and the output voltage is cut off. Even if the TEST signal is applied (or the TEST button is pressed) when in this state, the Tester does not perform its test operation. With this function, the operator can be protected against undesirable delivery of the test output voltage which could be caused by undesirable external conditions or inadvertent external operations.

A schematic diagram of the control circuit is shown in Figure 4.9. When the contact shown in Figure 4.9 is open, the Tester is in the PROTECTION state. When the contact is closed and the RESET signal is applied (or the RESET button is pressed), the Tester is reset and the TEST ON operation is enabled.

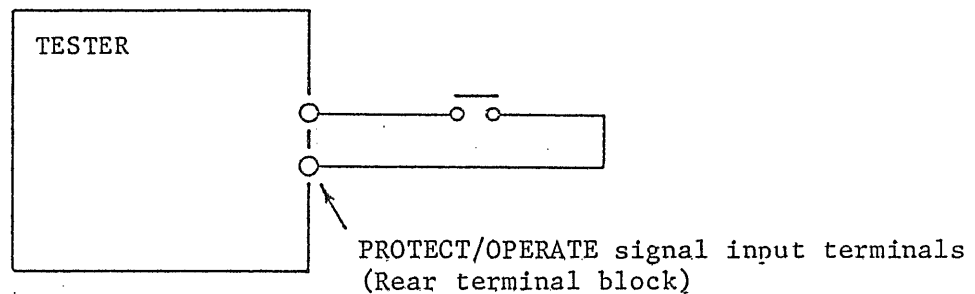

Figure 4.9

The Tester is shipped with these terminals shorted with a shorting bar.

89 R 298

4.3.5 Output Signals

- (1) The Tester provides the following signals in addition to the lamp and buzzer signals.

	Name of signal	Condition for generating the signal	Type of signal
①	TEST	During test period	Make-contact signal Ratings: 100 V AC, 1 A 30 V AC, 1 A
②	GOOD	For 200 msec when test is over	
③	NG	When NG judgment is made	

- ① TEST ON signal: This signal is generated and remains on for the entire period of the test.
- ② GOOD signal: This signal is generated when the GOOD judgment is done at the end the test with the timer. The signal lasts for approximately 200 msec.
- ③ NG signal: This signal is generated when the NG judgment is done. The signal lasts until the next RESET signal is applied.

(2) Contact Signals

- ① The contact signals are only with contacts and without any power sources as shown in Figure 4.10. Therefore, they cannot drive any loads which have no own power sources.

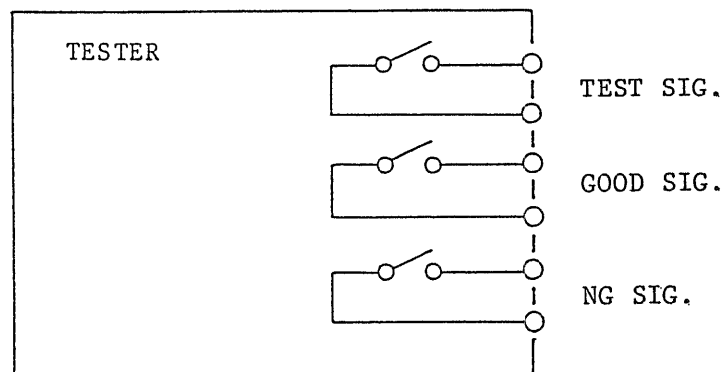

Figure 4.10

895394

A contact which is closed when the signal is applied is called make contact, normally open contact, or form "a" contact. A contact which opens when the signal is applied is called break contact, normally closed contact, or form "b" contact.

The contacts of this instruments are of the make-contact type and their rating is 100 V AC, 1 A or 30 V DC, 1 A. The withstanding voltage between the circuit and the chassis is 500 V AC, 1 minute.

② Examples of uses of contact signals are shown in the following:

- To drive a DC buzzer with the NG signal

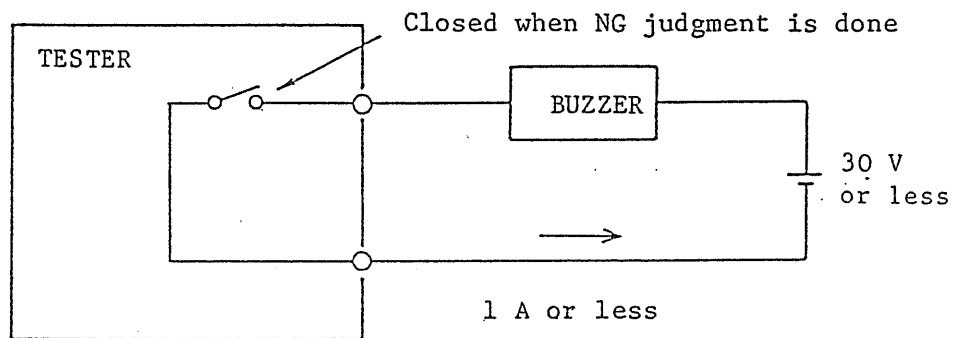

Figure 4.11

- To drive a lamp with the TEST signal

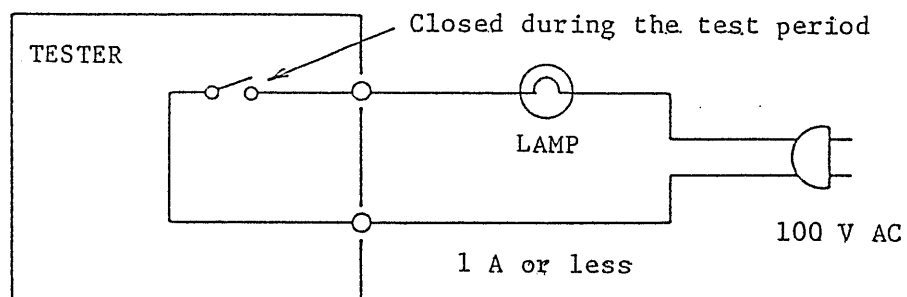

Figure 4.12

895395

- To obtain an "L" level digital signal with the contact signal

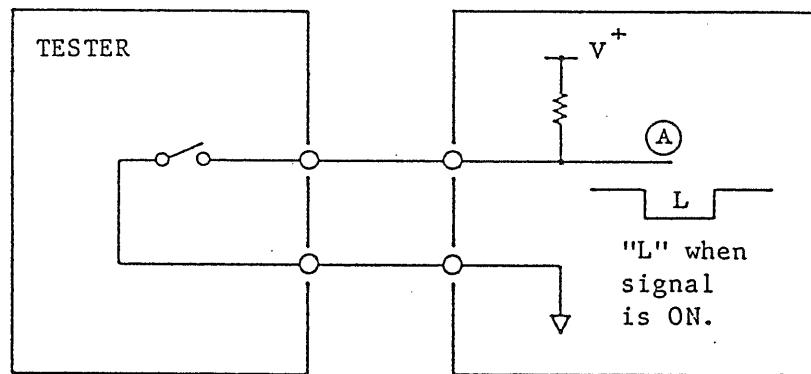

Figure 4.13

In the above illustration, an "L" level signal is obtained at point (A) when the contact output signal is on. However, since the signal obtained at point (A) involves chattering, an appropriate chattering suppression provision should be incorporated depending on the nature of the circuit to be driven by this signal. In some cases, a noise suppression provision may be necessary.

895396

③ Precaution on using the contact signal

Before using this contact signal, provide a contact protection measure (to absorb surge) suitable to the using method. Failure can not only cause malfunction of the circuit being connected later but also break the contact of the tester.

The figure 4.14 and 4.15 are the examples of the contact protection method recommended.

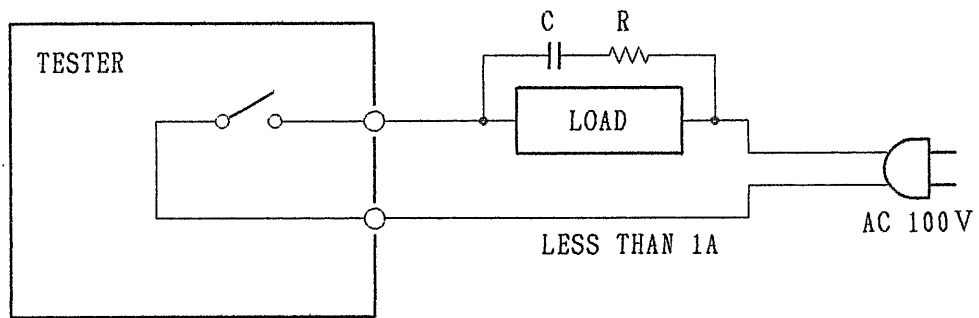

R: Approx. 100Ω 2W or over

C: Approx. $0.1\mu\text{F}$ AC 250V or higher

(The R and C are reference values only. Select proper values in accordance with the actual conditions.)

Figure 4.14

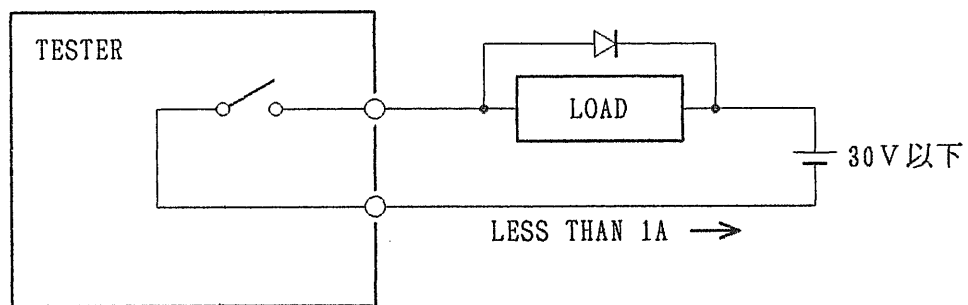

Diode

Reverse voltage 200V or higher

Forward current 1A or more

(The diode ratings are reference value only. Select proper values in accordance with the actual conditions.)

Figure 4.15

895397

4.3.6 Special Mode Settings for Sequences, Etc.

This instrument is capable of being set for five special modes for sequence operations, etc. Mode settings can be accomplished with the DIP switches on solder side of the PC board located in a left-hand position in the casing.

The standard switch setting (the setting for standard operation of the instrument, as set when the instrument is shipped) is as shown in Figure 4.16. By changing the settings of individual switches (1 - 4), settings can be made for the four different modes (1) - (4) as explained in the following. Since modes (1) - (5) are mutually independent, they can be set in any combinations as required.

Standard setting

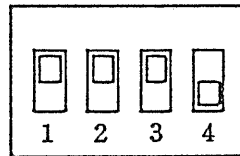

Figure 4.16

(1) Double-action test-on function

Setting of the switches for the double-action test-on function is as shown in Figure 4.17.

Double-action
test-on setting

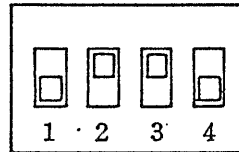

Figure 4.17

When in the standard mode, the Tester becomes the TEST ON state when the TEST button is pressed after the RESET button has been pressed. When in the double-action test-on mode, the Tester does not become the TEST ON state unless the TEST button is pressed within approximately 0.5 sec after the RESET button has been pressed. That is, the test operation does not start simply by pressing the TEST button alone but it starts only when both RESET and TEST buttons are pressed in a close sequence. Thus, while the procedure is more complicated, a high operation safety can be attained. This function is effective also when in the remote control operation.

(2) GOOD signal hold function

Setting of the switches for the GOOD signal hold function is as shown in Figure 4.18.

GOOD signal hold
function setting

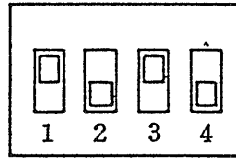

Figure 4.18

When the Tester is set in the standard mode and it has made a GOOD judgment, it generates a GOOD signal for about 200 msec. When the Tester is set in the GOOD signal hold mode, the GOOD signal lasts until the RESET signal is applied. The GOOD signal is delivered in the forms of a lamp signal, a buzzer signal, and a make-contact signal. Of these signals, the lamp signal and make-contact signal are discriminated between the GOOD signal and NG signal. The buzzer signal, on the other hand, is used in common for both GOOD and NG signals. The can be discriminated, however, by the levels of loudness of the buzzer sound.

(3) Momentary test-on function

Setting of the switches for the momentary test-on function is as shown in Figure 4.19.

Momentary test-on
function setting

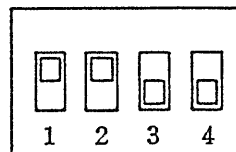

Figure 4.19

When the Tester set in the standard mode, once you have pressed the TEST button, the TEST ON state continues until the period set by the timer elapses or until you press the RESET button. When the Tester is set in the momentary test-on mode, the Tester is held in the TEST ON state only during the period the TEST button is kept depressed. At the instant the TEST button is released, the test operation stops. Thus, as your hand is held up by the TEST button during the period the test is on, a high safety of test operation can be attained.

895399

Still higher safety is attainable by using Model 914A Remote Control Box (both-hand type control box) in conjunction with this momentary test-on function.

When in the timer mode of operation and the period set by the timer has elapsed, the Tester generates a GOOD signal for about 200 msec and the test operation terminates. If you keep depressed the TEST button, the test will start again when the period of about 200 msec has elapsed. So, release your hand from the TEST button immediately when the GOOD signal is generated.

Never touch the D.U.T., the test leadwires, the output terminals or other electrically charged parts when you are keeping depressed the TEST button.

(4) Current limiting off function (regulation of the Tester)

Do not use this function when in the DC mode, so far as avoidable. Setting of switches for the current limiting "off" function is as shown in Figure 4.20. (In the following, the items enclosed in the parentheses are for Model TOS8700.)

Current limiting
off function
setting

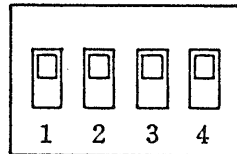

Figure 4.20

When the tester is set for AC operation in the standard mode, a current limiting function is provided for the CUTOFF CURRENT ranges of 0.5 - 10 mA, by inserting a resistor of approximately 5 ohms (7 ohm) in the primary circuit of the high voltage transformer in order to suppress the high regulation by providing a certain level of current limiting effect in case of shorting of the load or other abnormal cases, thereby enhancing the operation safety and preventing damage to the D.U.T..

When the Tester is set in the current limiting "off" mode, the current limiting resistor is shorted with a relay so that a high regulation is attained. When the current limiting resistor is inserted, the regulation for current change from 10 mA to no load with the CUTOFF CURRENT

895300

set at 10 mA and the output voltage set at 5 kV (10 kV) is approximately 6% (13%). When the current limiting function is off, the regulation under the same conditions is approximately 2% (approximately 3%).

Except when there are special needs, operate the Tester in the standard mode (current limiting "on" mode) from the viewpoint of safety of the operator and prevention of damage to devices.

However, when the CUTOFF CURRENT is set at 10 mA and the MULTIPLIER function is used or when the CUTOFF CURRENT is set at 100 mA (50 mA), the current limiting resistor is not inserted even if the Tester is set in the standard mode.

If in the DC mode, even when in the standard setting, the current limiting resistor is shorted by the relay immediately after the instrument is driven into the TEST ON state, regardless of CUTOFF CURRENT range setting. Therefore, the current limiting function is not effective when in the DC mode. On the contrary, if the current limiting function is set to "OFF" when in the DC mode, it is possible that overshoots of approximately 10% are produced when the instrument is driven into the TEST ON state. If it is unavoidable to operate instrument in the "current limiting function OFF" state, be sure to observe the following procedure.

- ① Turn the TEST VOLTAGE dial to the counterclockwise extreme position ("0" position).
- ② Press the TEST button.
- ③ Gradually raise the output voltage to the required value by turning clockwise the TEST VOLTAGE dial.

(5) NG ALARM function

The DIP switch of this mode setting is on parts side of the PC board located in a left-hand position in the casing.

NG ALARM setting

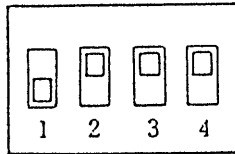

Figure 4.21

For the NG ALARM mode, set the switches as shown in Figure 4.21. When the Tester is set in the standard mode, as a remote RESET signal is applied, the test voltage is cutoff and the NG alarm and PROTECTION state and GOOD signal are reset as in the case that the RESET button on the front panel is pressed. When in the NG ALARM mode, as a remote RESET signal is applied, although the output is cutoff and the GOOD signal is reset, the NG alarm and the PROTECTION state are not reset. To reset the NG alarm and PROTECTIONS state, press the RESET button on the front panel.

This mode provides an effective means for confirming the NG alarm when Model HTP-1.5A or HTP-3A High Voltage Probe (optional) is used.

191.6.19

895402A

5. OPERATING PRINCIPLE

5.1 Block Diagram

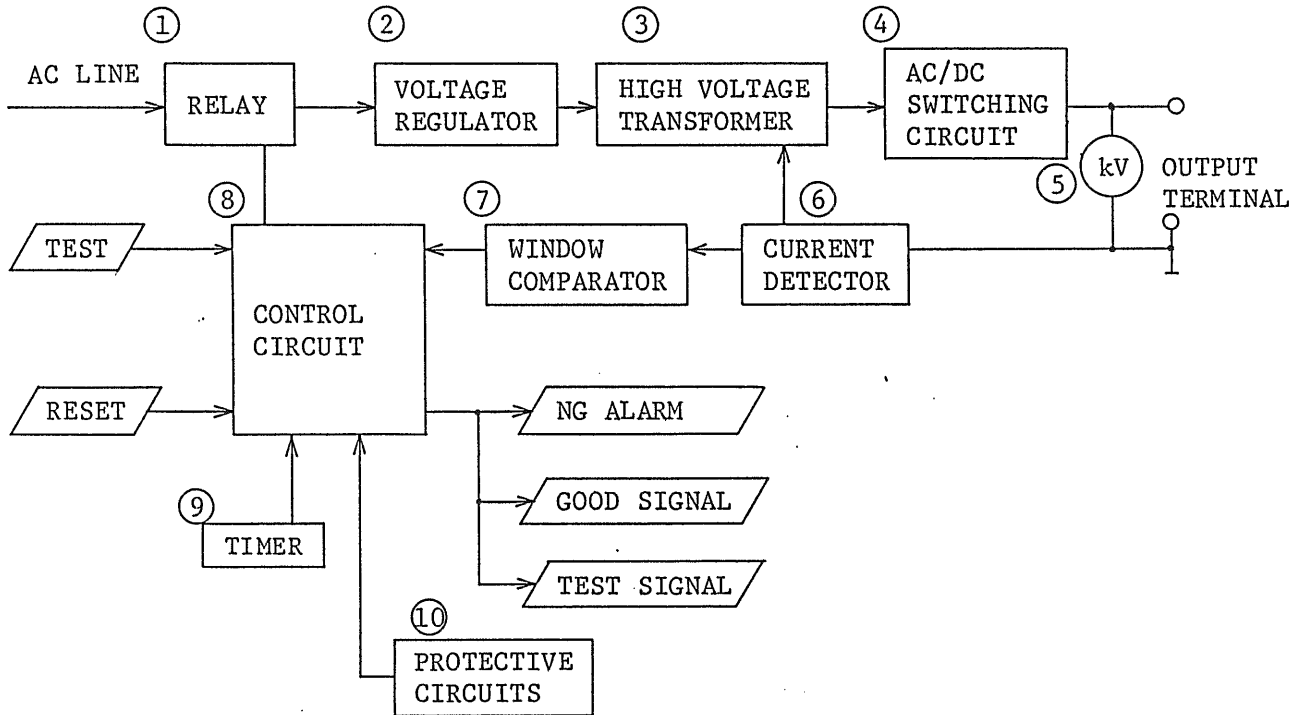

Figure 5.1

5.2 Descriptions of Individual Circuits and Components

① Relay:

On-off controls the power applied to the voltage regulator for withstanding voltage test. A solid-state zero-turn-on type relay circuit is employed to minimize transiential spike voltages caused when the relay is turned on or off.

② Voltage regulator:

A slide transformer is used to control the output voltage.

895403

③ High voltage transformer:

Boosts the voltage regulator output with a ratio of approximately 1:15 or 1:50 (1:30 or 1:100) into a high output voltage of 0 to 1.5 kV or 0 to 5 kV (0 to 3 kV or 0 to 10 kV). The AC rating is 5 kV, 100 mA (10 kV, 50 mA), 500 VA. (The values enclosed in the parentheses are for Model TOS8700.)

④ AC/DC switching circuit:

Selects between the AC output voltage and the DC output voltage by relays for high-voltage use.
(The TOS8700 employs a high-voltage rotary switch.)

⑤ Voltmeter:

Indicates the output voltage (the voltage of the output terminal).

⑥ Current detection circuit:

Consists of a full-wave-rectifier diode bridge circuit, current detecting resistors for respective ranges, and an integrating circuit.

⑦ Window comparator:

Consists of a reference voltage generator circuit, and a high and a low comparator circuit. Makes GO-NOGO judgment.

⑧ Control circuit:

Controls overall sequence operations of the instrument. Employs high-reliability logic circuits with CMOS IC.

⑨ Timer

To set the the test time.

⑩ Protection circuit:

Various protective features are incorporated for the safety of test. But be careful to operate. When the protection circuit has tripped, the output voltage is cut off.

5.3 Zero-turn-on Switch

If a regular mechanical contact type relay is used for on-off operation of the primary circuit of the high voltage transformer, transient spike voltages may be produced, thereby applying an unjustifiedly high voltage to the D.U.T. and causing a possibility of rejecting an acceptable D.U.T or damaging it. The zero-turn-on switch, which employ a solid-state switching circuit, turns on and off the power line at approximately 0 volt level, thereby reducing transient overshoots.

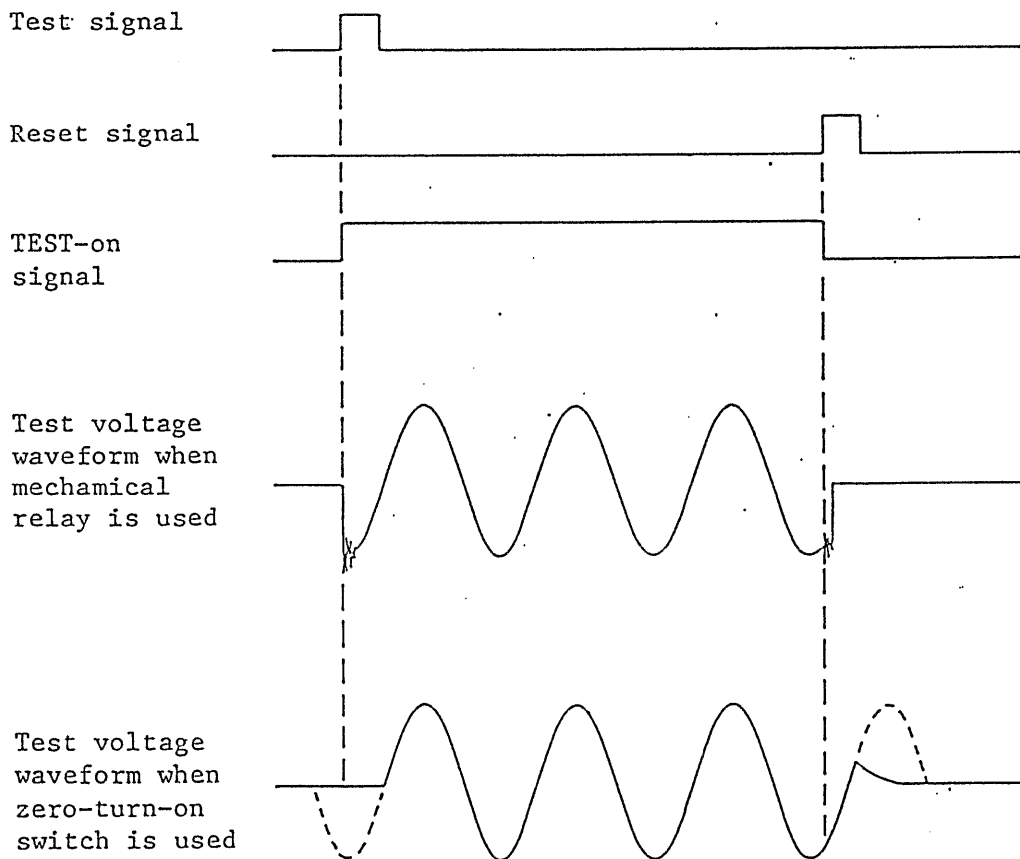

Figure 5.2

— High-Voltage Test Probe and It's Usage Instruction —

Two test probes, HTP-1.5A & HTP-3A, are available as optional.

A test probe shall be processed in the following sequence on completion of a testing;

- 1.) turn off the switch of the probe, and then
- 2.) release the contact pin of the probe from the D.U.T. after confirming the LED on probe has been OFF

It is empharized that the probe shall NOT be processed in the reverse order (2.) & 1.)), or it will spoil the "zero" switching besides it is unsafe.

6. MAINTENANCE

6.1 Cautions

*A hazardously high voltage of a level of 5 kV *(10 kV) is generated by this instrument. Never attempt to repair the instrument for yourself. For such service, contact your Kikusui agent.*

This section covers the calibration procedure of the instrument. Be extremely careful not to touch the electrically charged parts.

* (The items marked with an asterisks and enclosed in parentheses are for Model TOS8700. Applicable to section 6 "MAINTENANCE," throughout.)

6.2 Calibration

This section explains the calibration procedures of the voltmeter and the CUTOFF CURRENT value (except that for the low-limit reference value).

(1) Meters and Resistors Required for Calibration

- ① Voltmeter I : A voltmeter which is capable of measuring 5 kV *(10 kV), AC (50/60 Hz) and DC, with an accuracy of approximately 1%. (Kikusui model 149-10A, for example)
- ② Voltmeter II : A voltmeter which is capable of measuring 2.5 V DC, with an accuracy of 0.1%.
- ③ Milliammeter: A milliammeter which is capable of measuring 0.5, 1, 2, 5, 10, and 100 *(50) mA AC (50/60 Hz) and DC, with an accuracy of approximately 1%.
- ④ Load resistors: Resistors as shown in Table 6.1, for calibration of CUTOFF CURRENT values. The resistors for the points the calibration of which is omitted are not required.

Table 6.1

Cutoff current [mA]	Load resistor	
	Resistance [Ω]	Power consumption [W]
0.5	2M	0.5
1	1M	1
2	500k	2
5	200k	5
10	100k	10
100 *(50)	10k *(20k)	100 *(50)

Note 1: The working voltage ratings of the resistors must be 1 kV AC or over. The accuracies of resistances must be 5% or better.

Note 2: The resistances must have wattages with sufficient allowances for the above-mentioned power consumptions.

(2) Preparation and Notes Before Starting Calibration

- ① Before turning on the power switch, perform mechanical zero adjustment of the voltmeter.
- ② Turn on the power switch and allow a stabilization period of approximately 15 minutes or over.
- ③ The Testers can be operated either with an AC or an DC output voltage, by switching. In the subsequent explanation, the output voltage mode is not discriminated between AC and DC. Use a voltmeter and a milliammeter corresponding to the output voltage mode. The calibration methods are identical for both modes but the parts numbers of the semi-fixed potentiometers are different. [The parts numbers of the semi-fixed potentiometers for the DC mode are enclosed in brackets, hereafter.]
- ④ The semi-fixed potentiometers are located on the PC board at the left-hand side in the casing. The layout of the potentiometers is shown in Figures 6.3 and 6.4.

895408

(3) Calibration of Voltmeter

- ① Set the switches and knob on the front panel of the Tester as follows:
 - TEST VOLTAGE switch: 1.5 kV *(3 kV)
 - TIMER ON/OFF switch: OFF
 - LOWER ON/OFF switch: OFF
 - TEST VOLTAGE knob: Counterclockwise extreme position ("0" position)
- ② Connect a standard voltmeter to the output terminal, set the Tester to the TEST ON state, and adjust the output voltage of the Tester so that the standard voltmeter indicates 1.5 kV *(3 kV).
- ③ Adjust RV105 [RV107] so that the pointer of the voltmeter of the Tester is deflected to the center of the 1.5 kV *(3 kV) scale position.
- ④ Reduce the output voltage to zero and change the TEST VOLTAGE switch to the 5 kV *(10 kV) position.
- ⑤ In a similar procedure as in Steps ② and ③, calibrate the 5kV *(10kV) range of the voltmeter with RV106 [RV108]. After the calibration is over, turn the TEST VOLTAGE dial to the counterclockwise extreme position ("0" position) and press the RESET button.

(4) Check of Voltmeter Indications

- ① At each of the 1.5kV/5kV "(3kV/10kV) ranges of AC/DC modes, check the indication of the Tester voltmeter with the standard voltmeter.
- ② Check the indications at the following measuring points:
 - 1.5kV range: 0.5,1,1.5 kV
*(3kV range: 1,2,3 kV)
 - 5kV range: 1,2,3,4,5 kV
*(10kV range: 2,4,6,8,10 kV)

Measuring points may be omitted, added, or changed depending on the purpose of calibration.

(5) Calibration of Cutoff Current (Leak Current Detection Sensitivity)

- ① Set the MULTIPLIER knob on the front panel of the Tester to the CAL'D position.
- ② Measure the voltage of pin 6 of U102 or TP106 with reference to TP100. Adjust the voltage to $2.5 \text{ V} \pm 0.2\%$ with RV104. For the TP (test point) numbers, see Figure 6.3 or 6.4.

(6) Check of Cutoff Current

- ① With the adjustment of Item (5) alone, the cutoff current should satisfy the accuracy of judgement to the specification. If it does not, the Tester is malfunctioning. No further adjustments than that of Item (5) can be made and the Tester needs repair service.
- ② Set the panel switches and knobs in the same manner as mentioned in Item (3), ①.
- ③ Connect a load resistor and a milliammeter which are corresponding to the set cutoff current, as shown in Figure 6.1 or 6.2. Select a resistance from Table 6.1 in conformity with the set current.
- ④ Set the Tester to the TEST ON state and gradually increase its output voltage until the Tester generates the NG signal at approximately 1 kV. Turn slightly the TEST VOLTAGE dial counterclockwise, set the Tester again to the TEST ON state, and increase the output voltage very slowly.
- ⑤ Read the current immediately before the NG signal is generated and the output is cut off.
- ⑥ For each of the cutoff current values to be tested, repeat the procedure of Steps ③ - ⑤.

Figure 6.1

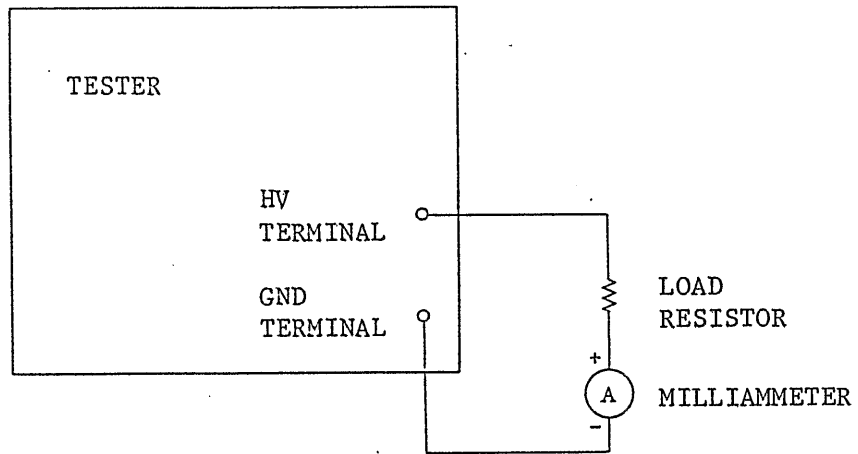

* Be sure to connect the milliammeter to the GND terminal side.

Figure 6.2

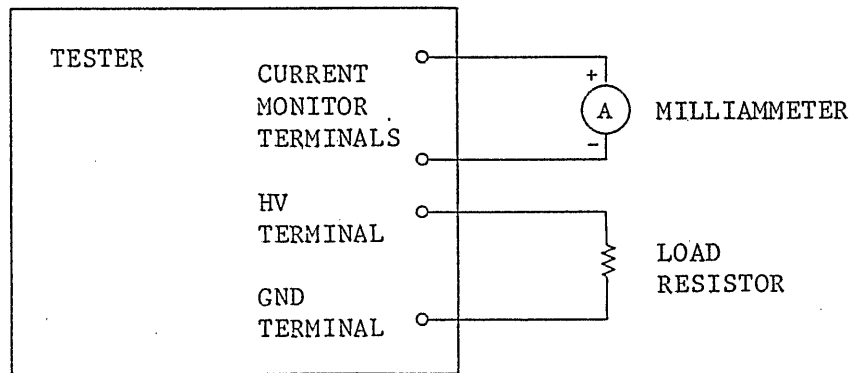

895411

Figure 6.3

TOS8750

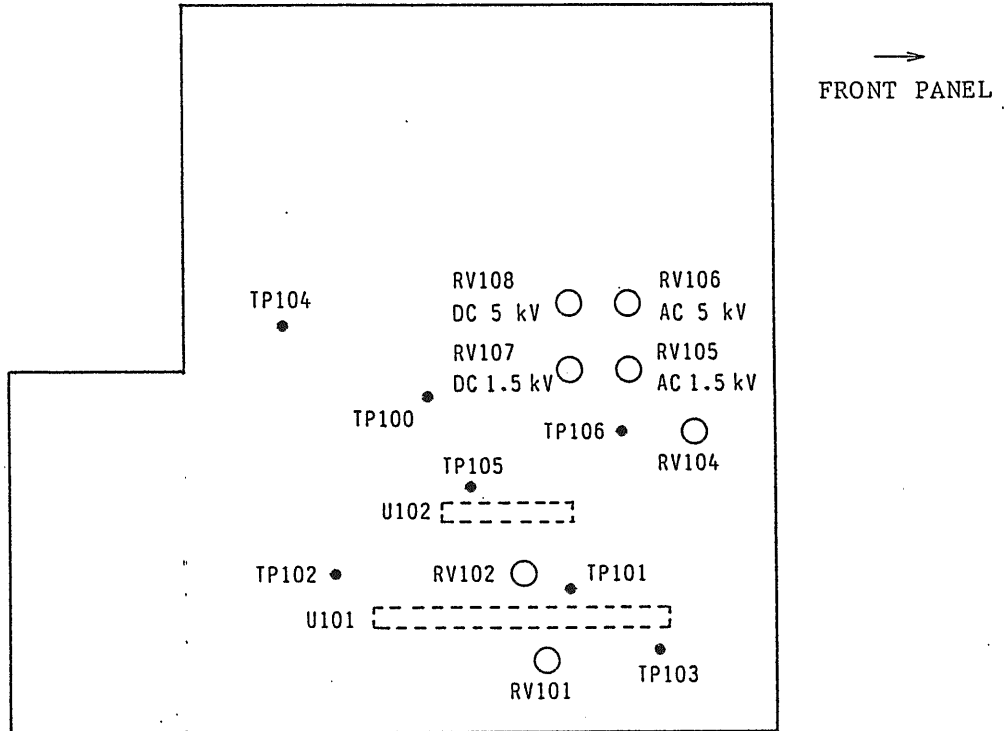
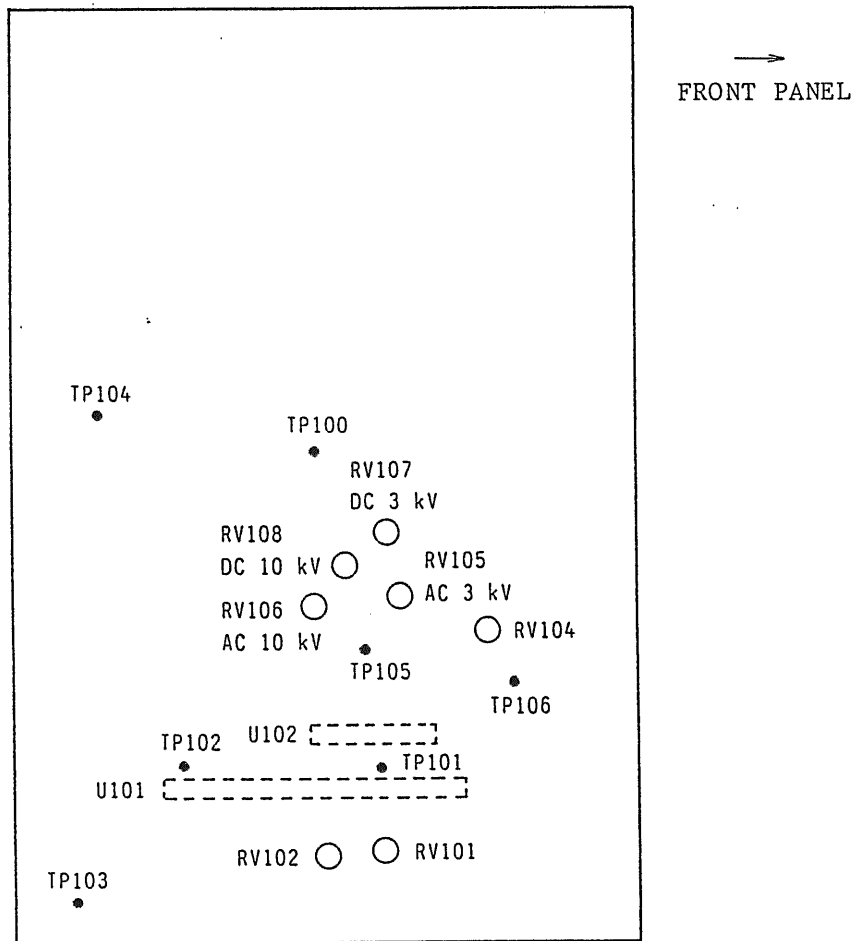

Figure 6.4

TOS8700



895412

7. OPTIONS

The following options are available for this instrument.

- Model 913A Remote Control Box

For remote control of test and reset operations.

Specifications

Functions

OPERATE switch:

The TEST button is effective only when this switch is ON. By turning OFF this switch, the output voltage is forcefully reset.

TEST button:

The test voltage is delivered as this button is pressed when the OPERATE switch is ON and the instrument is in the reset state.

RESET button:

This button is used to cut off the test voltage or to reset the NG alarm.

Dimensions: 150 (W) × 70 (H) × 40 (D) mm
(5.9 (W) × 2.8 (H) × 1.6 (D) in.)

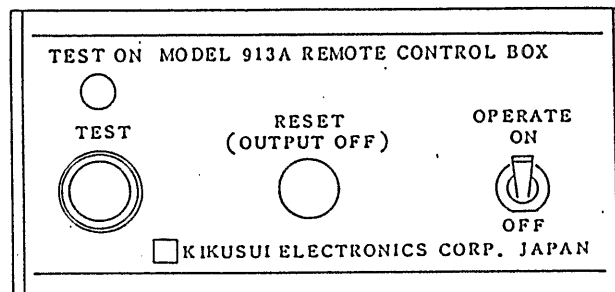

Figure 7.1

Model 914A Remote Control Box

With this control box, the test voltage is delivered only when the two test buttons are pressed simultaneously.

Specifications

Functions:

Has two TEST buttons and the output voltage is delivered only when the two buttons are pressed concurrently. Other functions are same as those of Model 913A.

Dimensions: 280 (W) × 70 (H) × 40 (D) mm
(11.0 (W) × 2.8 (H) × 1.6 (D) in.)

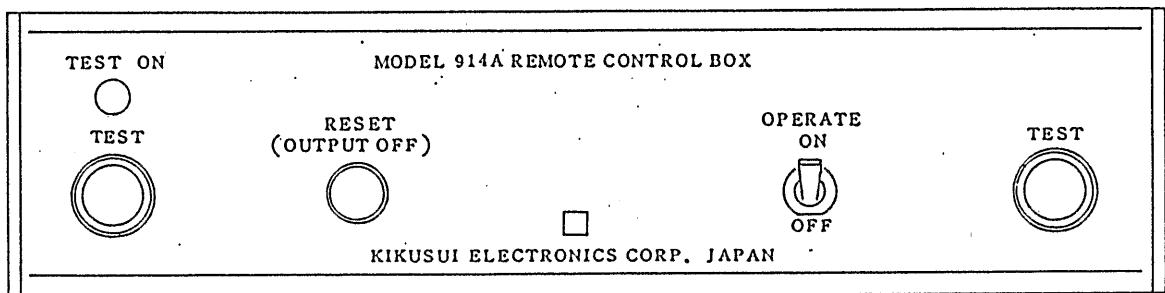

Figure 7.2

HTP-1.5A High Voltage Test Probe

The test switch can be pressed only after holding the grip, thereby preventing inadvertent turning on of the test voltage. When the test switch is released, the test voltage is reset forcefully.
(NG ALARM function is "OFF.")

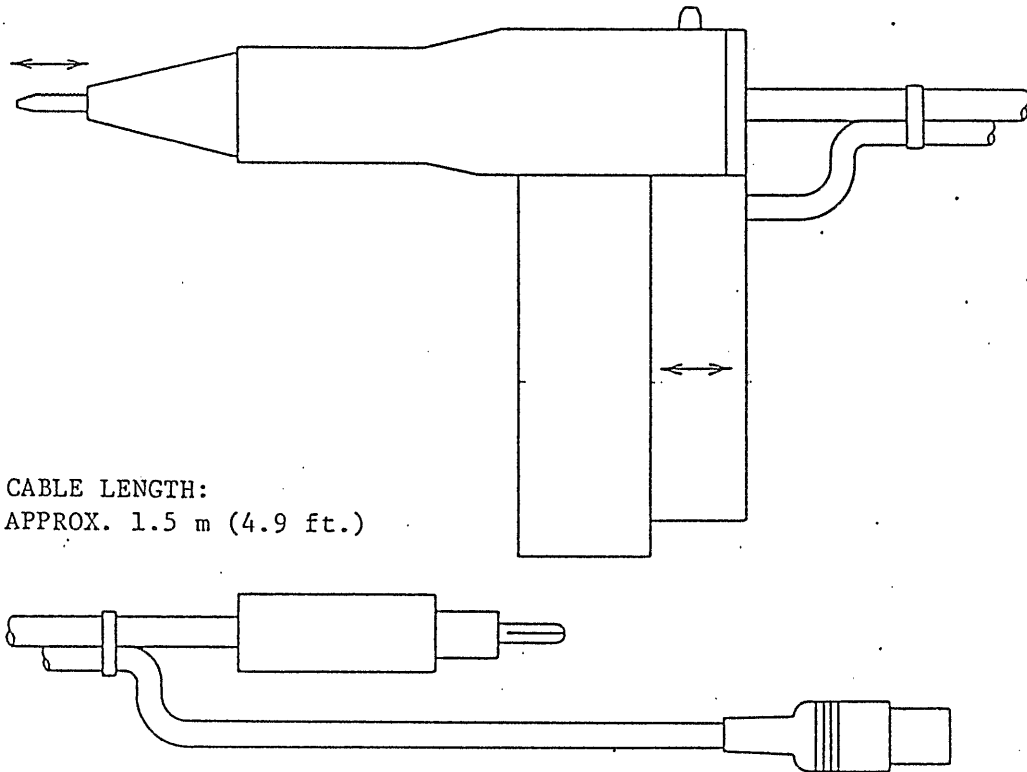

Figure 7.3

WARNING

- (1) *The maximum allowable working voltage of the probe is 5 kV. Never use it for measurement of voltages higher than 5 kV.*
- (2) *When making test, using these probes for UL Standards, employ the "NG ALARM function" of the tester (see page 41).*

HTL-3W High Voltage Test Leadwire

The maximum allowable working voltage of the test leadwire is 5 kV. Never use it for measurement of voltages higher than 5 kV. The test leadwire is 3 meters (9.8 ft) long.

895415

Model 9202 Alarm Lamp Unit

This unit indicates that the Withstanding Voltage Tester is in the TEST ON state. This unit can be driven by the TEST ON signal (contact signal) of the Tester.

Model 9203 Buzzer Unit

This unit may be used when the sound generated by the buzzer housed in the Withstanding Voltage Tester is not sufficient. This unit can be driven by the NG alarm signal (contact signal) of the Tester.

895416*